



## FOAM PROPORTIONING EQUIPMENT

### ATMOSPHERIC FOAM STORAGE TANK

#### DESCRIPTION

Buckeye provides Atmospheric Foam Concentrate Storage Tanks manufactured in stainless or carbon steel, fiberglass and polyethylene. Vertical tanks are normally manufactured with flat bottoms and dome tops and horizontal tanks sit on saddles.

All tanks offered by Buckeye are suitable for use with Buckeye manufactured and supplied foam concentrates. The fiberglass and polyethylene tanks do not have expansion domes due to the dome shape at the top of the tank. Inspection hatches are provided on both style tanks. Regardless of the material of construction, a pressure/vacuum vent must be installed. This is normally installed on the inspection hatch on the fiberglass or molded polyethylene tanks and on the cover of the expansion dome on the carbon or stainless steel tank.

Fig. 16 shows a typical tank made from carbon steel.

#### IMPORTANT

If using a carbon or stainless steel tank with AFFF concentrate, it is strongly recommended by Buckeye NOT to internally line the inside of the tank shell. The reason is that the tank and the liner have differing coefficients of expansion during various ambient temperature cycles. Over time, pin holes may develop in the lining. AFFF having a very good wetting ability, will penetrate the pin holes and get in between the lining and the tank shell. Eventually portions of the lining may flake off and travel into the foam concentrate system, subsequently blocking orifices or strainers. Fig. 17 shows a custom built tank in 316 stainless steel. Other configurations are available. Contact the engineering department at Buckeye for further assistance.

Upon receipt of the Buckeye manufactured/ supplied Atmospheric Foam Concentrate Storage Tank and before any installation, inspect the tank for any damage that may have occurred during shipping. Report any damage to Buckeye immediately.

#### INSTALLATION

If the tank has been received in a satisfactory condition, locate the tank in the desired location, level it and if necessary, anchor to the floor. If possible, leave an area around the tank free from any walls, obstacles or electrical panels. This gives a safe working space for connecting the foam system piping to the tank.

Fig. 7 shows a typical piping arrangement of a foam concentrate pump, atmospheric tank supplying an in-line balanced pressure proportioning system.

#### IMPORTANT

Buckeye does not supply any interconnecting piping, strainers or valves, that are not specifically mentioned on any quotation or order acknowledgment.

Fig. 9 illustrates the typical piping layout for a pump pressure proportioning skid system.

#### IMPORTANT

When using AFFF or AR-AFFF type foam concentrates in any atmospheric type storage tank, it is recommended by Buckeye that after filling the tank with the correct quantity of foam concentrate a thin layer (approximately 1/4 inch) of a quality mineral oil be placed on the surface of the foam concentrate. This alleviates the problem associated with evaporation of the foam concentrate.



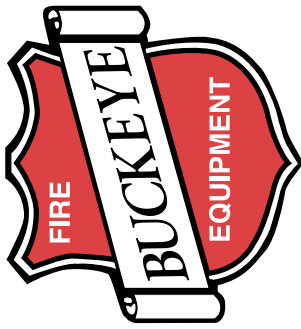

# FOAM PROPORTIONING EQUIPMENT

## ATMOSPHERIC TANK

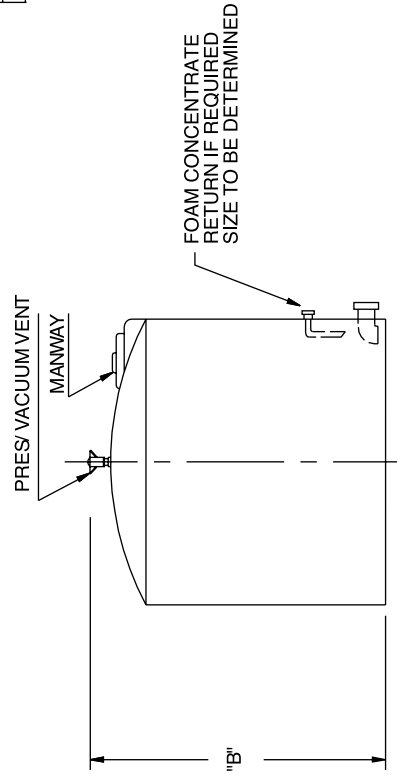
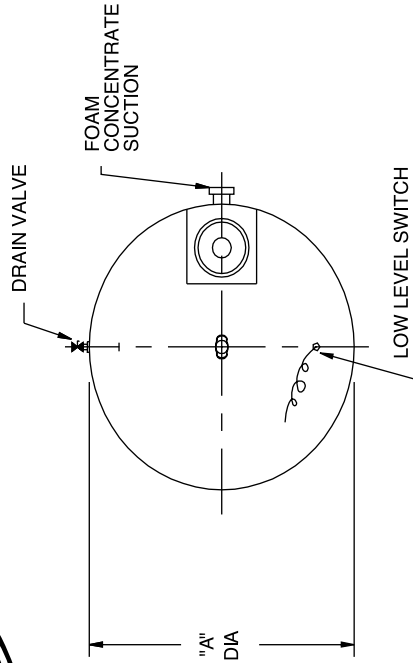

CAPACITY GALS.	DM "A" IN. (MM)	DM "B" IN. (MM)
200	31 (787)	78 (1982)
300	46 (1168)	59 (1500)
400	46 (1168)	80 (2032)
550	48 (1219)	89 (2260)
800	48 (1219)	124 (3150)
950	64 (1625)	90 (2266)
1200	64 (1625)	106 (2692)
1450	64 (1625)	128 (3251)
1850	96 (2438)	82 (2083)
2400	96 (2438)	99 (2514)
2900	96 (2438)	117 (2972)
4000	94 (2134)	159 (4038)
4200	102 (2591)	145 (3683)
5000	93 (2312)	198 (5029)
5500	112 (2845)	150 (3610)
6400	120 (3048)	150 (3610)
7000	120 (3048)	174 (3854)
8000	143 (3633)	140 (3556)
10000	143 (3633)	177 (4495)
12000	132 (3353)	202 (5130)

FLANGE SIZE	
SUCTION	XX
RETURN	XX
DRAIN	XX
LEVEL SWITCH	XX

## POLYETHYLENE FOAM STORAGE TANK