



FOAM PROPORTIONING EQUIPMENT

PRESSURE SUSTAINING VALVE

DESCRIPTION

The Buckeye pressure sustaining valve is used in Balanced Pressure Foam Proportioning Systems to maintain a set system pressure. The valve is used in combination with the foam concentrate pump to maintain consistent upstream pressure regardless of system demand.

SPECIFICATIONS

The basic valve is single seated, line pressure operated, diaphragm actuated, pilot controlled globe valve. The valve is sealed by means of a corrosion resistant seat and resilient, rectangular seat disc. These and other parts are replaceable in the field; and all such service and adjustments are possible without removing the valve from the system pipe work. The stem of the valve is guided top and bottom by integral bushings. All internal and external ferrous surfaces are coated with a high quality, two part epoxy primer; the exterior then receives a coat of baked enamel paint.

The pilot control system includes a direct acting, normally closed, spring loaded diaphragm actuated pilot valve with the stem guided between the diaphragm assembly and seat disc. To ensure precise pressure regulation, the appropriately rated pilot valve is field adjustable within the pressure control range of the spring, such adjustment not to exceed a ratio of 6:1. The valve with the appropriate pilot in place is operationally and hydrostatically tested prior to shipping and carries a one-year limited warranty against failure due to defects in workmanship or materials.

FEATURES

- The valve is provided with a custom engineered sensing line **Push-Over** feature to ensure that foam concentrates do not congeal in the pilot actuation system, rendering the valve inoperable.
- Quickly relieves excess pressure or back pressure.
- Operates automatically from line pressure normally-closed, direct-acting, spring-loaded pilot for pressure adjustments between 100- 300 psi, using a single adjusting screw.

- Heavy-duty, nylon reinforced, viton diaphragm isolates upper chamber operating pressure from lower chamber line pressure.
- Diaphragm assembly, guided top and bottom, is the only moving part of the main valve.
- No packing glands or stuffing boxes to allow leaking of control fluid.
- Rectangular soft seat provides drip-tight seal for extended valve service.
- Easily repaired and adjusted without removal from the line.
- Inlet port tapping can be used for a pressure gauge.
- All valves are hydrostatically and flow tested prior to shipping with specified pilot set-points factory set.

OPTIONS

Model BF-PSV (Standard)

Main Valve: Body/Bonnet - Ductile Iron ASTM A536 (epoxy coated.)

Control Pilot: Body/Bonnet - Bronze B62

Tubing/Fittings: Copper/Brass

Model BF-PSVB (Brass)

Main Valve: Body/ Bonnet - Bronze

Control Pilot: Body/Bonnet - Bronze B62

Tubing/Fittings: Copper/Brass

Model BF-PSVSS (Stainless Steel)

Main Valve: Body/ Bonnet - Stainless Steel

Control Pilot: Body/Bonnet - Stainless Steel

Tubing/Fittings: Stainless Steel/Stainless Steel



ORDERING INFORMATION

BF-PSV (Valve size)
 BF-PSVB (Valve size)
 BF-PSVSS (Valve size)

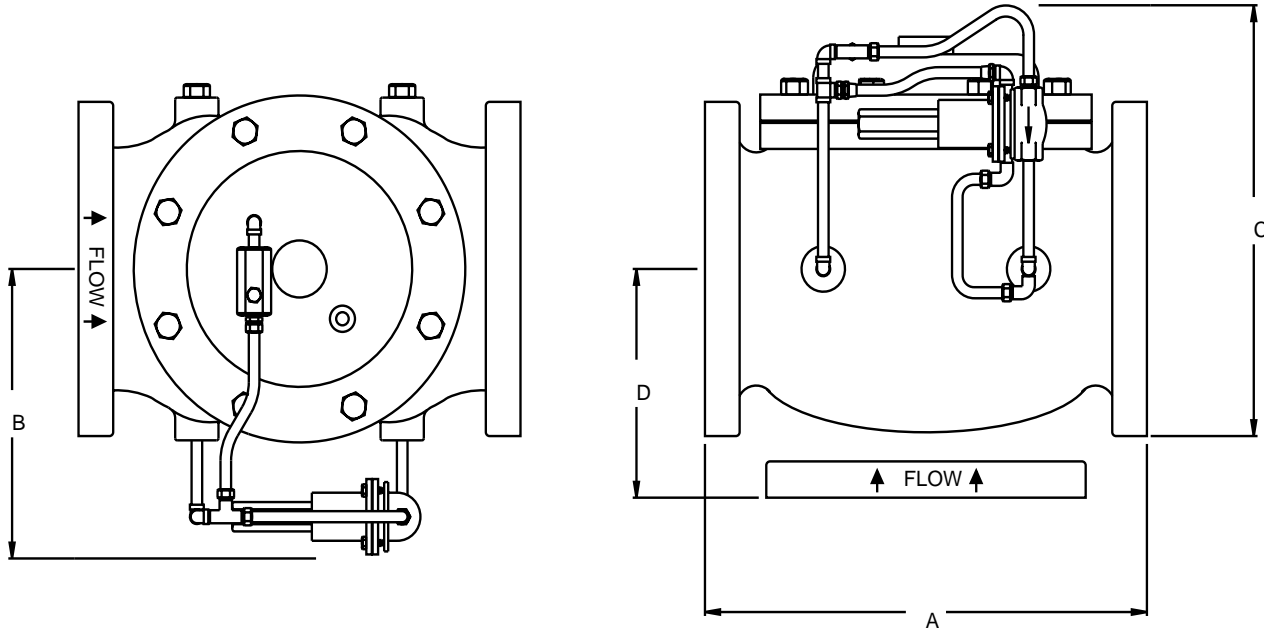

VALVE SIZE	FLOW RATES*	A	B	C	D	SHIPPING WEIGHT
1 1/4"	30 - 125 gpm	8 1/2 (216 mm)	9 (229 mm)	8 1/2 (216 mm)	3 (76 mm)	38 lbs. (18 kg)
1 1/2"	30 - 125 gpm	8 1/2 (216 mm)	9 (229 mm)	8 1/2 (216 mm)	3 (76 mm)	38 lbs. (18 kg)
2"	65 - 260 gpm	9 3/8 (238 mm)	10 (254 mm)	9 (229 mm)	3 7/8 (98 mm)	38 lbs. (18 kg)
3"	150 - 570 gpm	10 1/2 (267 mm)	12 (305 mm)	10 3/8 (264 mm)	4 (102 mm)	83 lbs. (38 kg)
4"	250 - 1000 gpm	13 1/2 (343 mm)	10 1/4 (260 mm)	12 1/2 (318 mm)	5 1/16 (128 mm)	156 lbs. (71 kg)
6"	550 - 2300 gpm	17 3/4 (450 mm)	12 (305 mm)	15 1/2 (394 mm)	6 (152 mm)	300 lbs. (137 kg)

* Recommended flow rates produce velocities less than 25 ft./sec. through the valve under most operating conditions.

MODEL 108-2SLF (BUCKEYE)

ITEM	PART NO.	QTY	DESCRIPTION
1	65	1	BASIC VALVE ASSEMBLY
2	1330	1	PRESSURE RELIEF PILOT
3	126	1	EJECTOR
4	300777	1	ORIFICE FITTING

