



NOZZLES / MONITORS

AIR ASPIRATED HANDLINE NOZZLE

DESCRIPTION

The Buckeye Air-Aspirating Handline Nozzle is designed to effectively entrain air into the foam/water solution by a modified venturi process. The aspirated foam provides excellent fire fighting performance and is ideally suited for application to polar solvents. Depending upon the type of foam concentrate used, expansion ratios of 5:1 up to 10:1 can be expected, with a nominal nozzle operating pressure of 100 psi (7 bar). The nozzles are manufactured in aluminum alloy and stainless steel, with a powder coated red finish.

Part No.

Flow gpm (lpm)

Inlet

PE 9956	60 (227)	1 1/2"
PE 9957	95 (360)	1 1/2"
PE 9958	125 (473)	1 1/2"
PE 2296	200 (757)	2 1/2"
PE 9959	250 (946)	2 1/2"

FEATURES

- U.L. Listed.
- High quality aspirated foam.
- Epoxy coated for longevity.
- A large handle controls the on/off function of the nozzle. It is designed to enable the firefighter to operate it while wearing gloves.
- Dual trunion drive on ball shut off - provides smoother shut off action and less maintenance.
- Anodized aluminum ball shut off - full flow type with EPDM seats.
- Lightweight construction allows comfortable operation by one person.
- Suitable for use with AFFF and AR-AFFF, protein, fluoroprotein or Class A foam solutions.
- Nozzle supplied with a ball bearing, swivel female NST inlet as standard.
- Option - other inlet threads available.
- Option - Self-educting feature for foam concentrate suction at the nozzle tip.
- Color coded pistol grip is standard



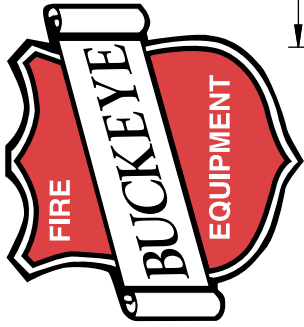

NOZZLES/MONITORS

AIR ASPIRATING FOAM TUBE

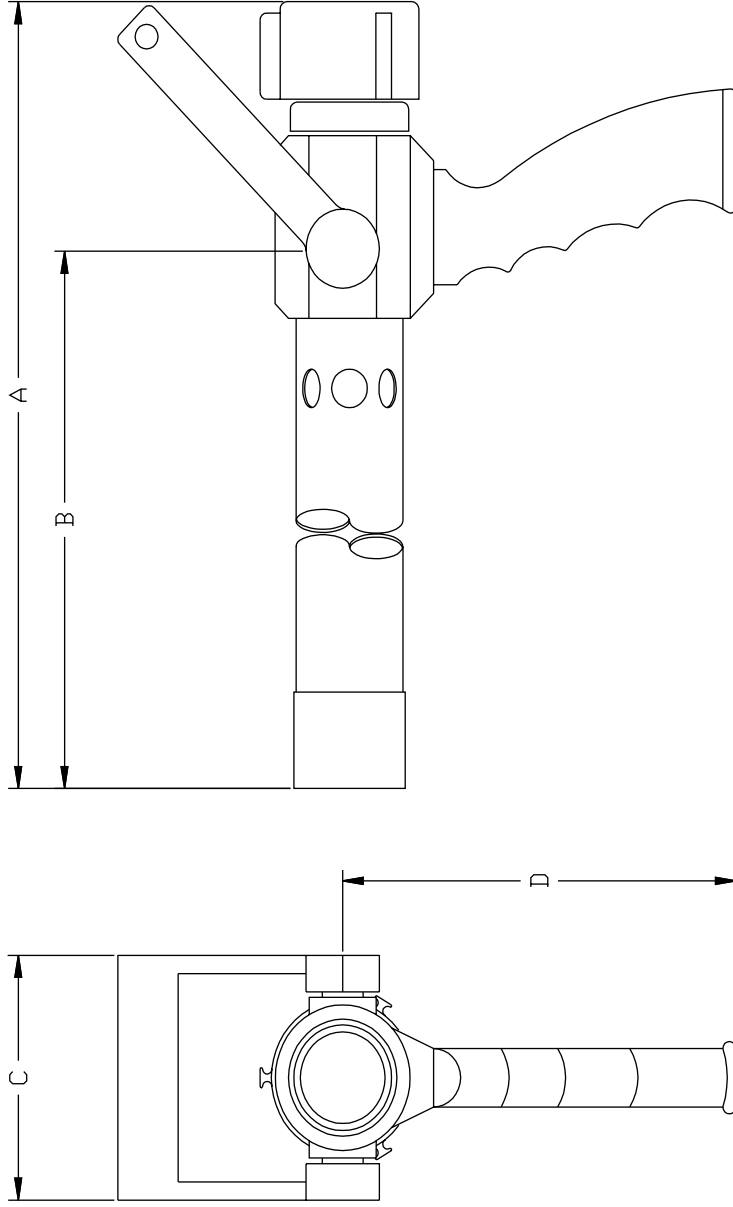

MODEL NO:	CONNECTION	FLOW	A	B	C	D	E (Horiz)	F (Vert)
PE-9956	1 1/2" NST	60 GPM (227)	25 7/8" (657)	22 3/8" (568)	4 1/2" (114)	6" 5/16" (160)	XXXX (XXXX)	XXXX (XXXX)



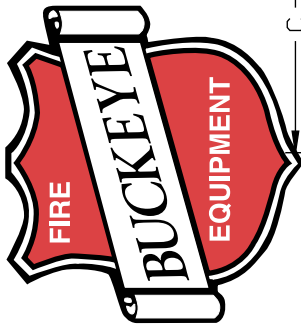

NOZZLES/MONITORS

AIR ASPIRATING FOAM TUBE

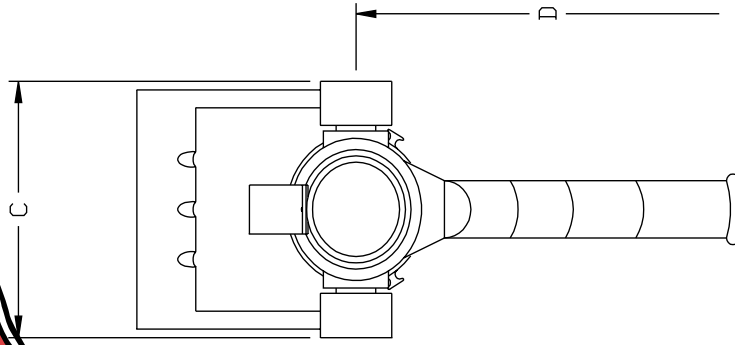
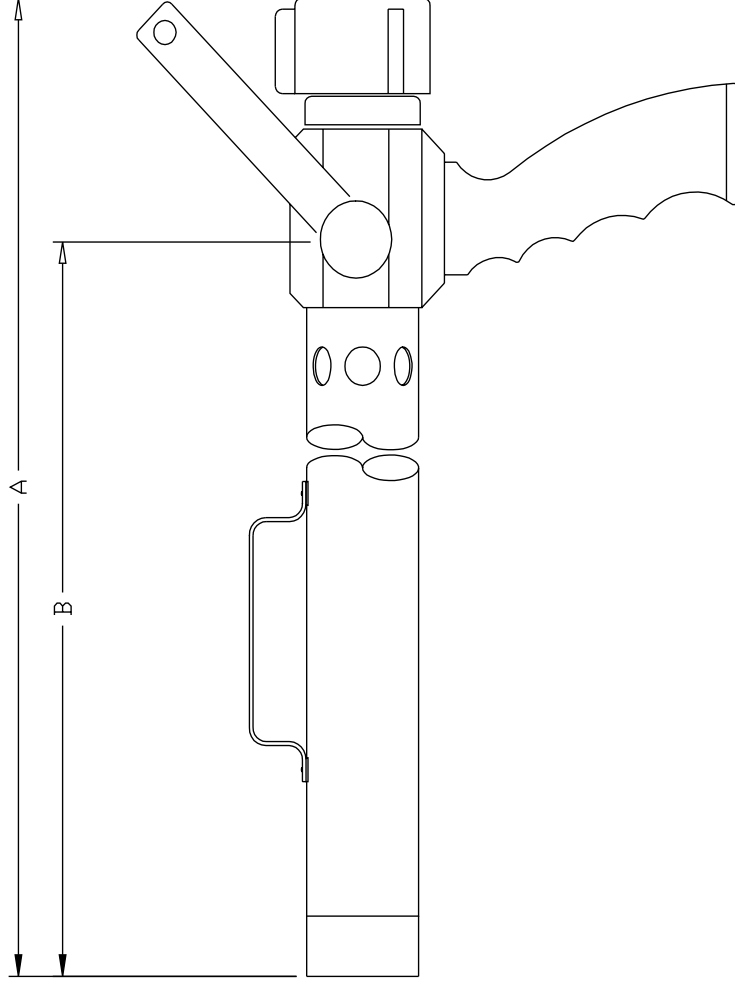

MODEL NO:	CONNECTION	FLOW	A	B	C	D	E (Horiz)	F (Vert)
PE -9957	1 1/2" NST	95 GPM (360)	27 1/2" (697)	24" (610)	5" (127)	6 5/16" (160)	XXXX (XXXX)	XXXX (XXXX)

