



NOZZLES/MONITORS

FIXED GALLONAGE MONITOR NOZZLES

DESCRIPTION

Manufactured from corrosion resistant brass, the Buckeye Master Stream Monitor Nozzle has been designed for use in harsh environments such as marine, industrial plants and offshore locations. Each nozzle is a single gallonage, constant flow device in any discharge pattern. All are suitable for use with water, Class Q, AR AFFF, or AFFF solution.

FEATURES

- Various gallonage selections available:
350, 500, 750 or 1000 gpm.
- Grease fittings for lubrication.
- 2 1/2" Female NST swivel base.
- Spacers are provided to field adjust the flow rate.
- Nozzles are fitted with teeth for greater dispersion of the water stream into a fog pattern.

ORDERING INFORMATION

BFMN 350	350 gpm Monitor Nozzle
BFMN 500	500 gpm Monitor Nozzle
BFMN 750	750 gpm Monitor Nozzle
BFMN 1000	1000 gpm Monitor Nozzle

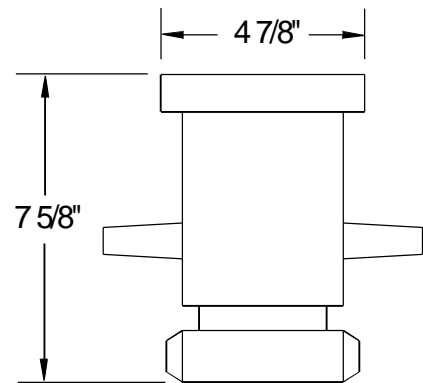
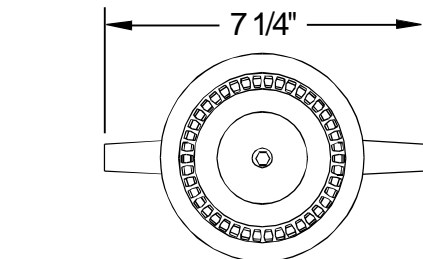

BFMN 350, 500, 750

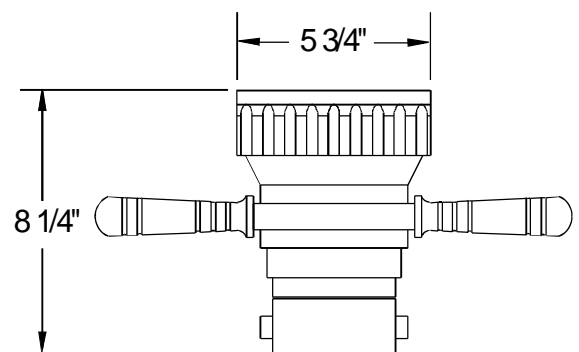
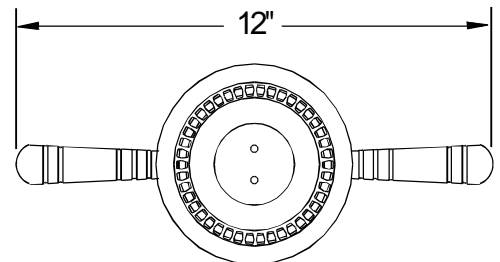

BFMN 1000



	NOZZLE PRESSURE psi	FLOW gpm	EFFECTIVE RANGE feet	OVERALL RANGE feet
350 gpm	80	305	130	137
	100	350	145	152
	120	380	150	158
500 gpm	80	460	165	173
	100	500	185	200
	120	565	195	210
750 gpm	80	670	210	225
	100	750	240	260
	120	815	245	260
1000 gpm	80	945	240	258
	100	1000	265	280
	115	1075	275	293

MONITOR NOZZLES

- Effective range is taken to the center point of the falling water footprint.
- Overall range is taken to the point where the final water droplets land.

The above discharge distances were established in ideal weather conditions with the nozzle at a 32' elevation above the horizontal. Ranges can vary depending on the weather conditions.

