



# FOAM CHAMBERS/MAKERS

## FOAM CHAMBERS

### DESCRIPTION

The Buckeye Foam Chamber consists of a foam expansion chamber and an integral foam maker. The foam chamber is installed on a flammable liquid storage tank just below the roof joint. The foam solution is piped to the Chamber from outside the hazard. Upon entering the chamber, the foam solution is expanded and then discharged against a deflector inside the storage tank. The deflector directs the foam against the inside wall of the storage tank. This reduces the submergence of the foam and agitation of the fuel surface. (N.F.P.A. Type II Application.)

### FEATURES

- Choice of four models to cover all flow requirements.
- Top of chamber has handle which simplifies inspection access to the vapor seal.
- Frangible glass vapor seal is provided. The glass is scored on one side and designed to break at a minimum 10 psi but not greater than 20 psi.
- Chamber manufactured in ASTM A366 carbon steel with a 304 stainless steel screen covering the foam maker air inlets.
- All foam chambers come with standard size flat faced flanges and gaskets.
- A choice of two styles of deflector are available (split or solid.)
- A stainless steel inlet orifice is supplied. The orifice is hydraulically calculated for the foam solution flow requirements and the foam solution inlet pressure available at the flanged inlet of the foam chamber.

### ORDERING INFORMATION

When ordering a Buckeye Foam Chamber specify the following:

1. The operating pressure required at the inlet of the chamber and foam solution flow rate to meet the design requirements of the system.  
(A minimum of 40 psi is required.)
2. Type of deflector required - solid or split.

### MODELS

### FLOW

BF FP 2.5	50 - 150 gpm
BF FP 3.0	100 - 300 gpm
BF FP 4.0	180 - 625 gpm
BF FP 6.0	395 - 1050 gpm

### FOAM CHAMBERS SHIPPING WEIGHTS

BF FP 2.5	Foam Chambers /Makers	60 lbs.
BF FP 2.51-2	Solid /Split Deflectors	5 lbs.
BF FP 2.53	Mounting Pad	15 lbs.
BF FP 3.0	Foam Chambers /Makers	100 lbs.
BF FP 3.01-2	Solid /Split Deflectors	10 lbs.
BF FP 3.03	Mounting Pad	20 lbs.
BF FP 4.00	Foam Chambers /Makers	145 lbs.
BF FP 4.01-2	Solid /Split Deflectors	20 lbs.
BF FP 4.03	Mounting Pad	35 lbs.
BF FP 6.00	Foam Chambers /Makers	270 lbs.
BF FP 6.01-2	Solid /Split Deflectors	30 lbs.
BF FP 6.03	Mounting Pad	50 lbs.





# FOAM CHAMBERS/MAKERS

## FOAM CHAMBERS

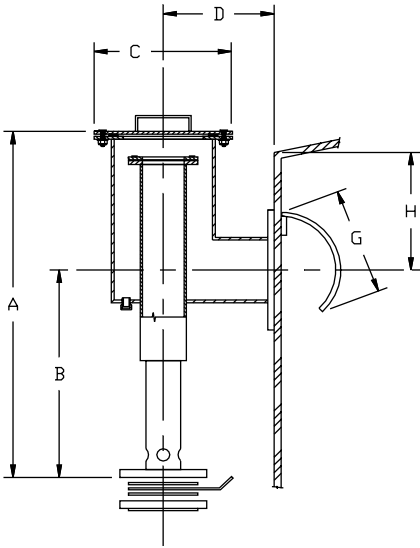

SIDE VIEW

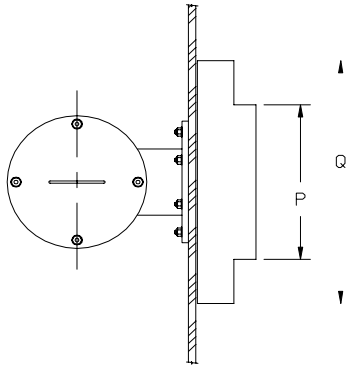

TOP VIEW

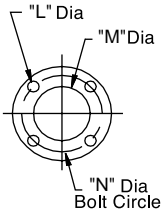

FC 2.5, 3

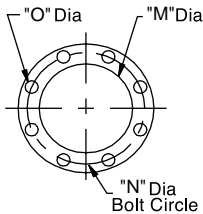

FC 2.5, 3, 4

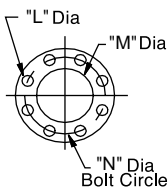

FC 4, 6

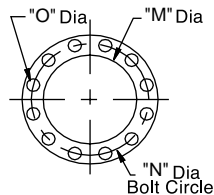

FC 6

"E" INLET FLANGE

"I" OUTLET FLANGE

### CHAMBER DIMENSIONS

	BF-FP 2.5	BF-FP 3	BF-FP 4	BF-FP 6
A	28-5/8"	34-5/16"	38-1/16"	44"
B	17-1/2"	22-1/4"	23-1/2"	25-3/8"
C	10-5/8"	12-3/4"	14-3/4"	18"
D	7"	9"	10"	12"
E	2-1/2"	3"	4"	6"
F	2"	3-1/4"	4-1/2"	5-1/2"
G	5-1/4"	8-1/2"	9-7/8"	11-1/2"
H	8"	9-1/2"	11"	12"
I	4"	6"	8"	10"
J	2-7/8"	3"	4-1/2"	6-5/8"
K	5-1/2"	6"	7-1/2"	9-1/2"
L	3/4"	3/4"	7/8"	7/8"
M	4-1/2"	6-5/8"	8-5/8"	10-3/4"
N	7-1/2"	9-1/2"	11-3/4"	14-1/4"
O	3/4"	7/8"	7/8"	1"
P	8"	12"	16"	20"
Q	12"	18"	24"	30"



# FLOW RANGE CHARTS BUCKEYE FOAM MAKERS & FOAM CHAMBERS

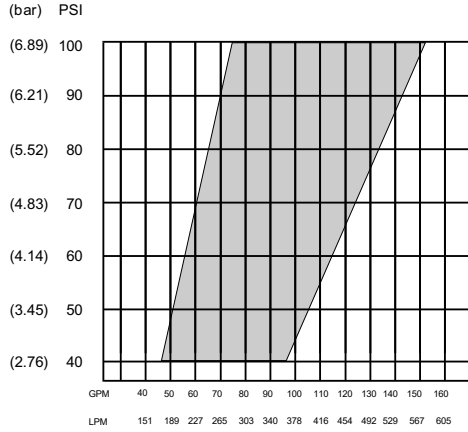

Flow @ 40 psi (2.8 bar) 47 - 97 gpm (178 - 367 lpm)  
 Flow @ 100 psi (6.9 bar) 75 - 153 gpm (284 - 579 lpm)

**BF-FP-2.5**

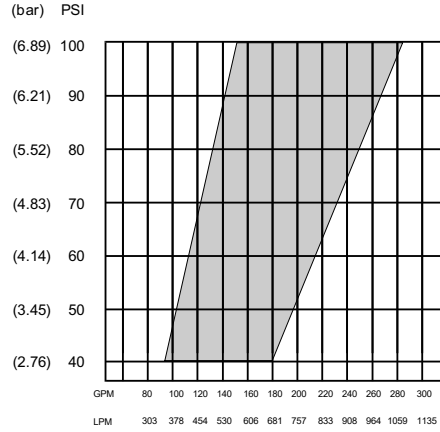

Flow @ 40 psi (2.8 bar) 96 - 179 gpm (363 - 678 lpm)  
 Flow @ 100 psi (6.9 bar) 152 - 283 gpm (575 - 1071 lpm)

**BF-FP-3.0**

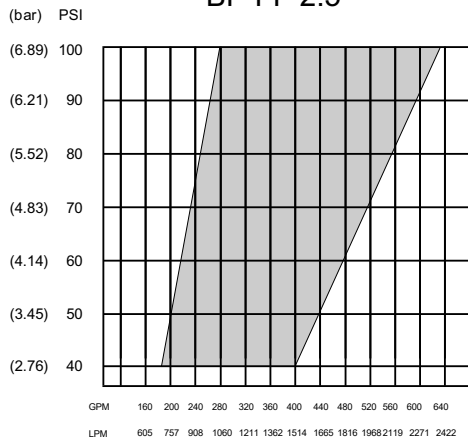

Flow @ 40 psi (2.8 bar) 179 - 397 gpm (678 - 1503 lpm)  
 Flow @ 100 psi (6.9 bar) 282 - 627 gpm (1067 - 2373 lpm)

**BF-FP-4.0**

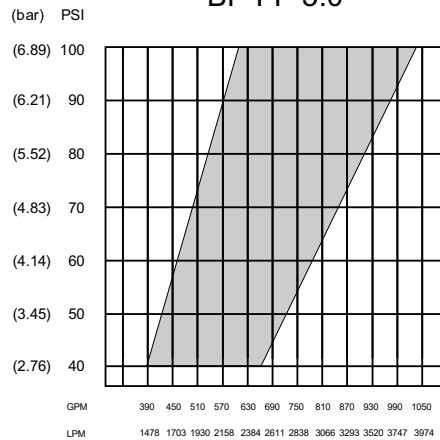

Flow @ 40 psi (2.8 bar) 393 - 655 gpm (1488 - 2479 lpm)  
 Flow @ 100 psi (6.9 bar) 620 - 1035 gpm (2347 - 3719 lpm)

**BF-FP-6.0**

NOTE: 1. Solution flow can be specified for any flow/pressure combination within the shaded area.  
 2. Flows noted at 40 and 100 psi (2.7 & 6.9 bar) are flows achieved through the smallest & largest orifice available for each device.

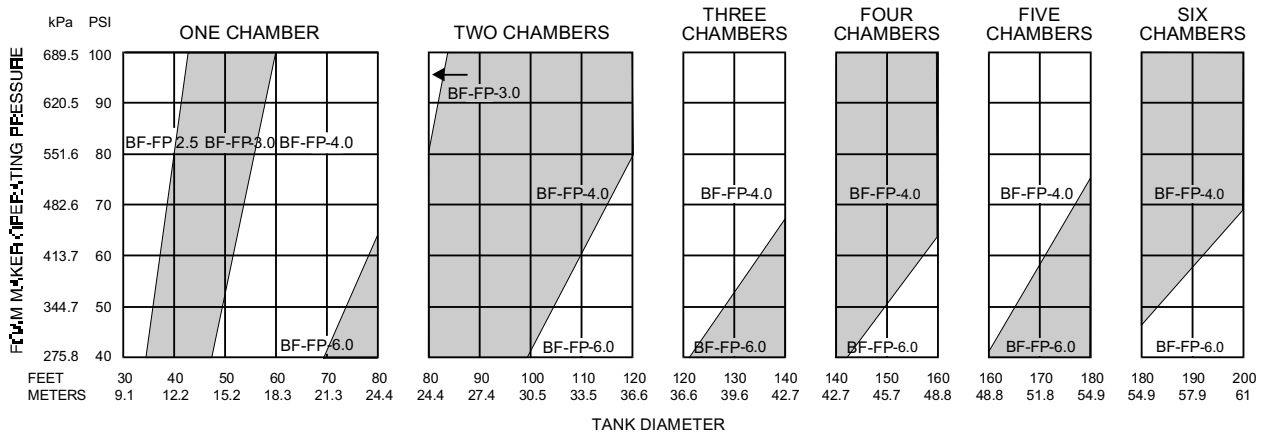

NOTE: SELECTION OF CHAMBER IS BASED UPON FOAM SOLUTION PRESSURE AT INLET TO FOAM MAKER. IF THIS PRESSURE IS MARGINAL, ALWAYS USE NEXT LARGEST CHAMBER SIZE.

