



FOAM PROPORTIONING EQUIPMENT

BALANCED PRESSURE PUMP PROPORTIONING SKID

DESCRIPTION

Buckeye Balanced Pressure Pump Proportioning Skids are designed to accurately proportion the foam concentrate into the water stream. The systems operate over a wide range of flows and pressures and do not require any manual adjustment.

FEATURES

- Five proportioner options to cover a wide range of flow requirements.
- Accurate proportioning is achieved by using a diaphragm type balancing valve.
- Schedule 40 Brass pipe is standard for all interconnecting piping. Options using stainless steel are available.
- Compatible for use with all Buckeye foam concentrates.
- Name tags used for all valve identification.
- Four lifting lugs provided for easy movement of the skid.
- Pump skid supplied with manual override capabilities.
- All Buckeye skids are fully tested and shipped from the factory ready to install.
- Choice of color and finish is available for all environments using either epoxy or enamel paint. Standard paint color is red.

SPECIFICATIONS

The Buckeye Balanced Pressure Proportioning Skid contains all necessary components including control valves, proportioning controller(s), duplex gauge, positive displacement foam concentrate pump with electric motor, motor starter and all interconnecting piping. The complete unit is mounted on a structural steel base for stability.

Optional drivers include diesel and gasoline.

FLOW RANGE

The following table lists the nominal flow range for each size Proportioning unit. The flow rates for other foam concentrates may vary. Consult the engineering department at Buckeye for specific applications.

FLOW RANGE

<u>SIZE</u>	<u>AR-AFFF</u>	<u>AFFF</u>
BF-BPSU 2.5	100 - 350	100 - 400 gpm
BF-BPSU 3	190 - 500	150 - 550 gpm
BF-BPSU 4	390-1300	350 - 1200 gpm
BF-BPSU 6	650-2900	550 - 2620 gpm
BF-BPSU 8	1550-4000	900 - 4200 gpm

ORDERING INFORMATION

When ordering a Buckeye Balanced Pressure Pump Proportioning Skid, the customer should supply the following information:

1. Type and percentage of foam concentrate.
2. Minimum and maximum static and residual water pressure available at the proportioning controller(s.)
3. Minimum and maximum foam solution flows expected.
4. Power supply required.
5. Type of paint finish and color.



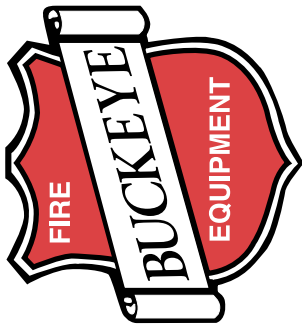

FOAM PROPORTIONING EQUIPMENT

SKID MOUNTED BALANCED PRESSURE SYSTEM

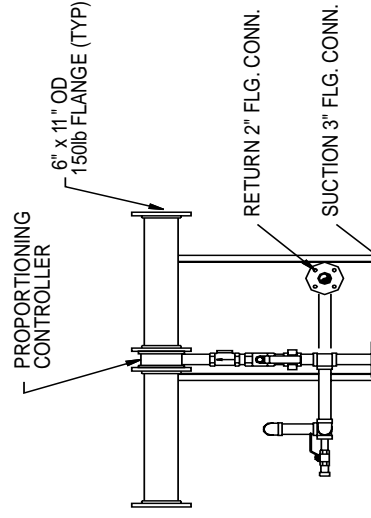
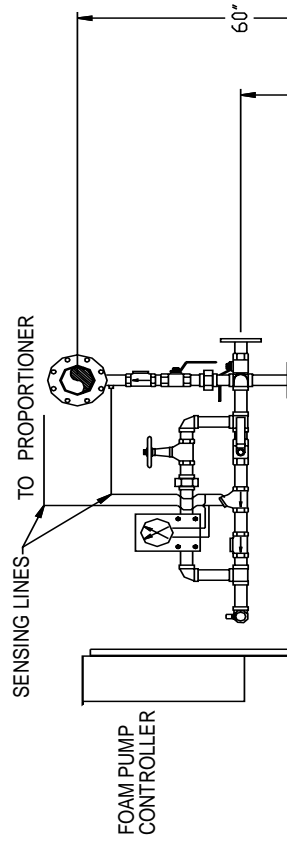
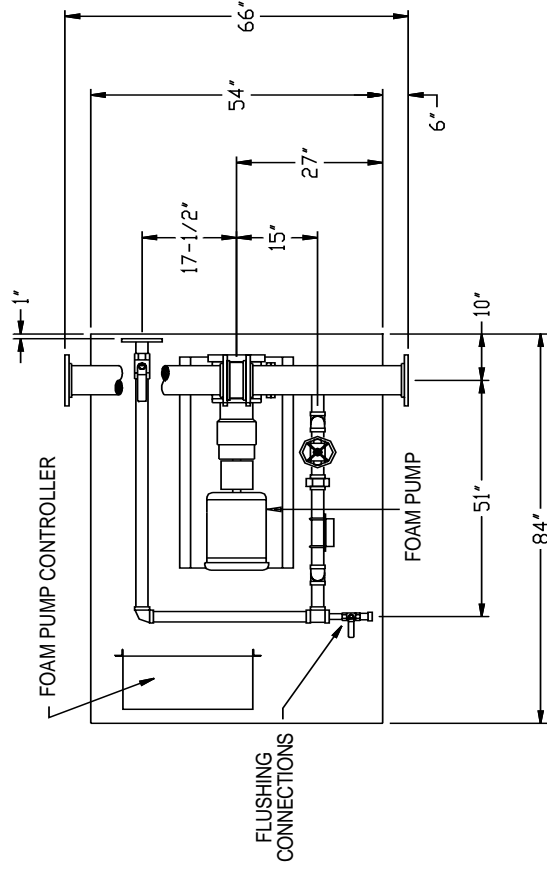

NOTES:

1. FOAM CONCENTRATE PIPE & FITTINGS TO BE BRASS.
2. PIPE SUPPORTS ARE NOT SHOWN FOR CLARITY.



FOAM PROPORTIONING EQUIPMENT

BALANCED PRESSURE PUMP SKID

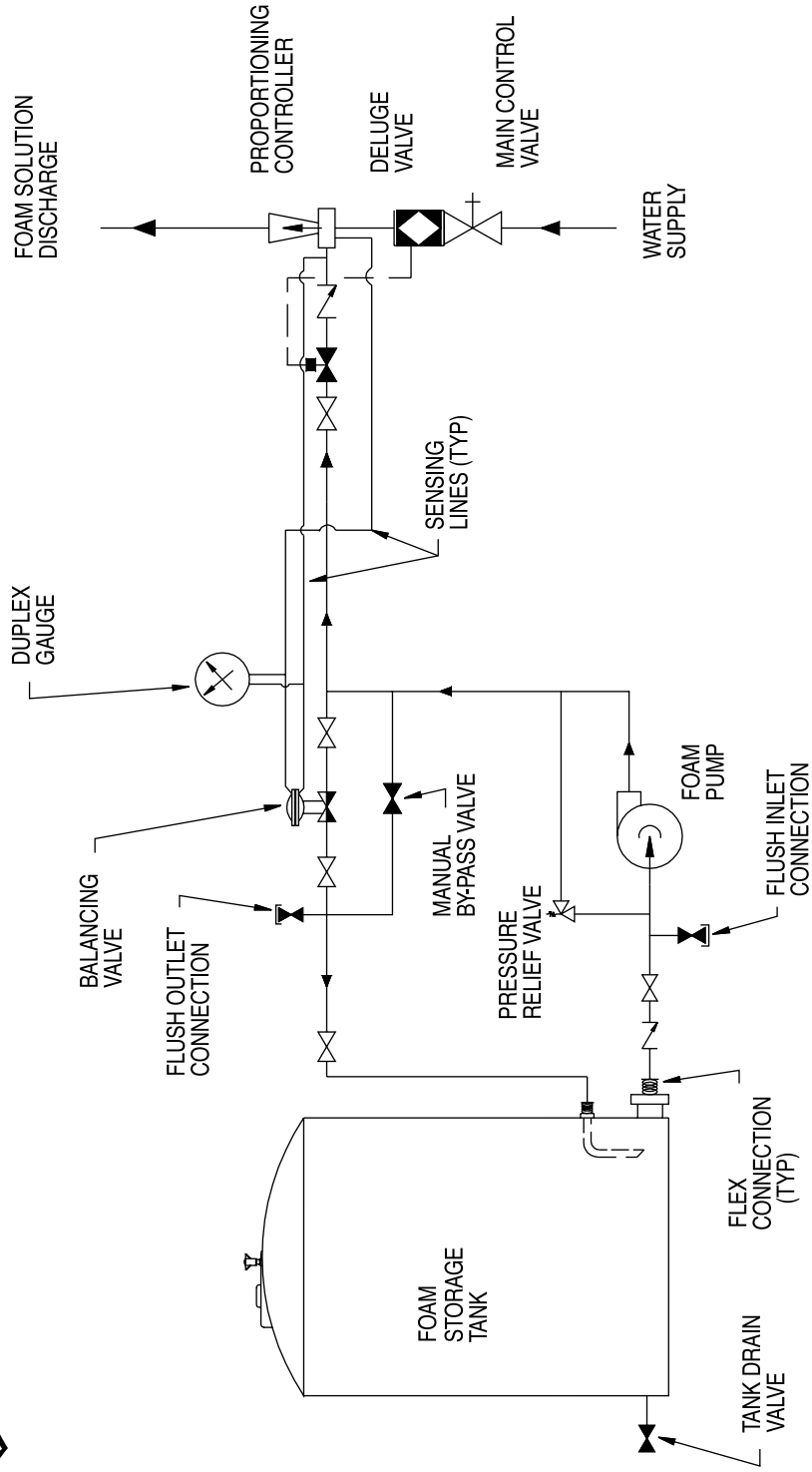

EXAMPLE OF BALANCED PRESSURE PUMP SKID WITH ONE PROPORTIONER



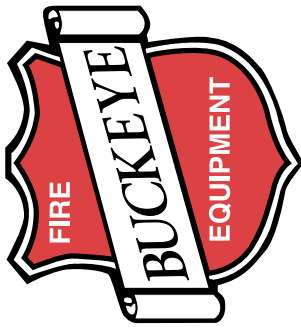

FOAM PROPORTIONING EQUIPMENT

BALANCED PRESSURE PUMP SKID

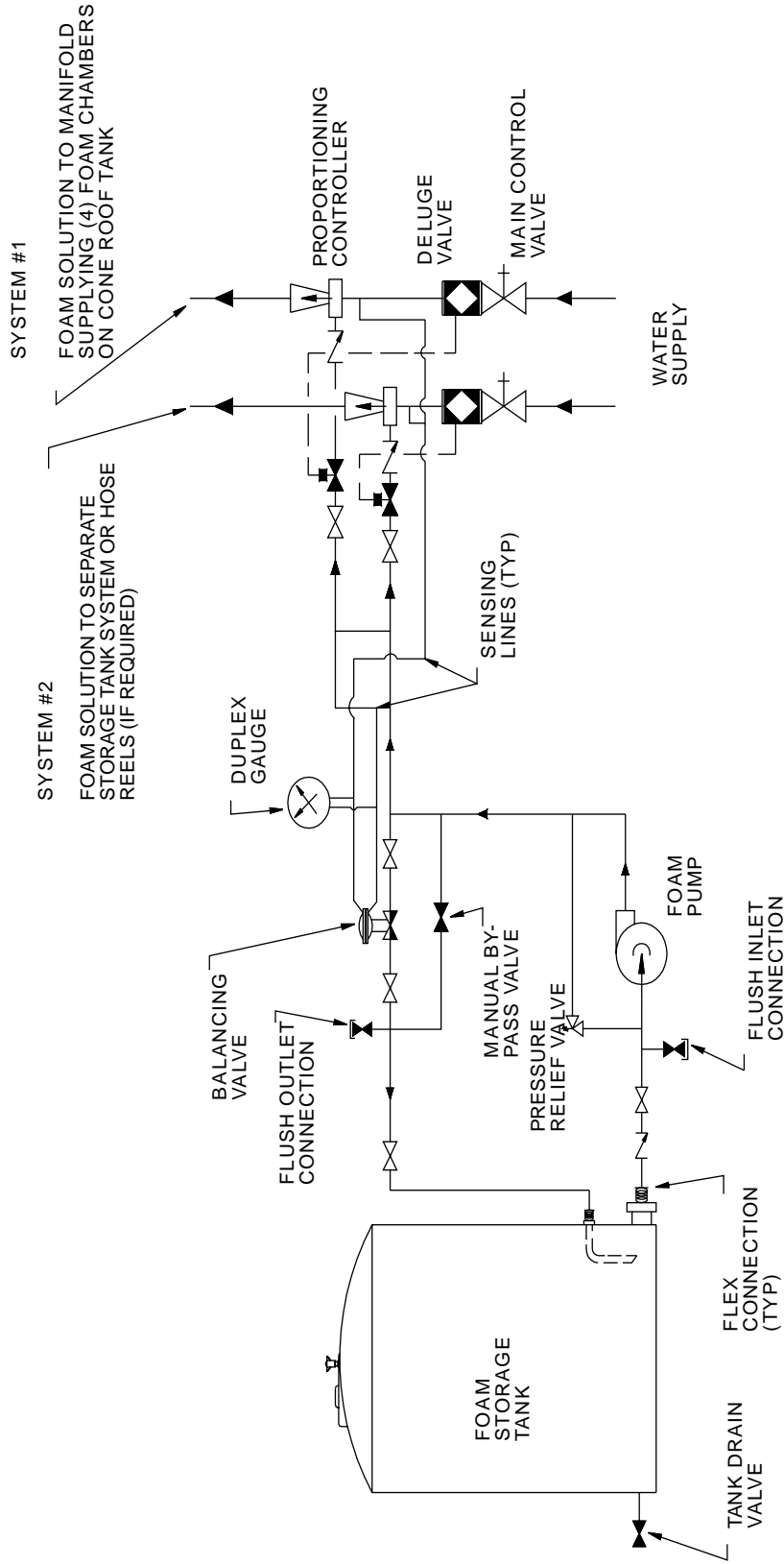

EXAMPLE OF BALANCED PRESSURE PUMP SKID WITH TWO PROPORTIONERS