

Kitchen Mister
Restaurant Cooking Area
Fire Suppression System



TECHNICAL MANUAL

Components
Design
Installation
Maintenance
Recharge

Buckeye Fire Equipment
110 Kings Road
Kings Mountain NC 28086

BFR-TM
ULEX 6885 ULC-EX 6885
February 1, 2020



TABLE OF CONTENTS

<u>SECTION/SUBJECT</u>	<u>Page</u>	<u>Rev</u>	<u>Date</u>
Table of Contents	i-1	6	2/1/2020
Index of Figures	ii-1	6	2/1/2020
Chapter 1, General Information			
Introduction	1-1	6	5/1/2019
How the <i>Kitchen Mister</i> Works	1-1	6	5/1/2019
System Temperature Limitations	1-1	6	5/1/2019
Listings and Approvals	1-1	6	5/1/2019
Manufacturer's Warranty	1-1	6	5/1/2019
System Installation and Maintenance Requirements	1-1	6	5/1/2019
Chapter 2, System Components			
Cylinder Sizes	1-2	6	2/1/2020
Model BFR-5	1-2	6	2/1/2020
Model BFR-10	1-2	6	2/1/2020
Model BFR-15	1-2	6	2/1/2020
Model BFR-20	1-2	6	2/1/2020
Valve Assembly	2-2	6	2/1/2020
Model BFR-VLV	2-2	6	2/1/2020
Valve Cap Assembly	2-2	6	2/1/2020
Model BFR-CAP	2-2	6	2/1/2020
Discharge Adaptor Kit	2-2	6	2/1/2020
Model BFR-DAK	2-2	6	2/1/2020
Extinguishing Agent	2-2	6	2/1/2020
Model BFR-5R	2-2	6	2/1/2020
Model BFR-10R	2-2	6	2/1/2020
Systems Releasing Modules	2-3	6	2/1/2020
Systems Releasing Modules - Mechanical	2-3	6	2/1/2020
Model SRM2-M	2-3	6	2/1/2020
Model SRM-D	2-3	6	2/1/2020
Model SRM	2-3	6	2/1/2020
Systems Releasing Modules - Electric	2-4	6	2/1/2020
Model SRM2-E-24	2-4	6	2/1/2020
Model SRM2-E-120	2-4	6	2/1/2020
Solenoid Monitor	2-5	6	2/1/2020
Model SM-24	2-5	6	2/1/2020
Model SM-120	2-5	6	2/1/2020
Microswitches	2-5	6	2/1/2020

<u>SECTION/SUBJECT</u>	<u>Page</u>	<u>Rev</u>	<u>Date</u>
Model MS-DPDT, Miniature Switch	2-5	6	2/1/2020
Model MS-AIS, Alarm Initiating Switch	2-5	6	2/1/2020
Fusible Links	2-6	6	2/1/2020
Model FL-280	2-6	6	2/1/2020
Model FL-360	2-6	6	2/1/2020
Model FL-450	2-6	6	2/1/2020
Model FL-500	2-6	6	2/1/2020
Thermal Detectors	2-6	6	2/1/2020
Model TD-225	2-6	6	2/1/2020
Model TD-325	2-6	6	2/1/2020
Model TD-450	2-6	6	2/1/2020
Model TD-600	2-6	6	2/1/2020
Nitrogen Actuation Cartridges	2-7	6	2/1/2020
Model BFR-AC-S	2-7	6	2/1/2020
Model BFR-AC-L	2-7	6	2/1/2020
Mounting Brackets	2-7	6	2/1/2020
Model MB-1	2-7	6	2/1/2020
Model MB-2	2-7	6	2/1/2020
Remote Mechanical Pull Stations	2-7	6	2/1/2020
Model RPS-M	2-7	6	2/1/2020
Model RPS-M-RM	2-7	6	2/1/2020
Mechanical Gas Shutoff Valves	2-8	6	2/1/2020
Model BFGV-75	2-8	6	2/1/2020
Model BFGV-100	2-8	6	2/1/2020
Model BFGV-125	2-8	6	2/1/2020
Model BFGV-150	2-8	6	2/1/2020
Model BFGV-200	2-8	6	2/1/2020
Model BFGV-250	2-8	6	2/1/2020
Model BFGV-300	2-8	6	2/1/2020
Fusible Link Bracket Kit	2-8	6	2/1/2020
Model FLB-1	2-8	6	2/1/2020
Fusible Link Holder	2-8	6	2/1/2020
Model FLH	2-8	6	2/1/2020
Buckeye Shielded Cable	2-8	6	2/1/2020
Model BFR-SC-100	2-9	6	2/1/2020
Shielded Cable Interface	2-9	6	2/1/2020

TABLE OF CONTENTS



<u>SECTION/SUBJECT</u>	<u>Page</u>	<u>Rev</u>	<u>Date</u>
Model BFR-SCI	2-9	6	2/1/2020
Compression Type Corner Pulley	2-9	6	2/1/2020
Model CPCT-1	2-9	6	2/1/2020
Discharge Nozzles	2-9	6	2/1/2020
Model N-1HP	2-9	6	2/1/2020
Model N-1LP	2-9	6	2/1/2020
Model N-2HP	2-9	6	2/1/2020
Model N-2LP	2-9	6	2/1/2020
Model N-2W	2-9	6	2/1/2020
Swivel Nozzle Adaptor	2-9	6	2/1/2020
Model N-SA	2-9	6	2/1/2020
Pipe and Fittings	2-9	6	2/1/2020
Components List	2-10	6	2/1/2020
Chapter 3, System Design			
Overview of System Design	3-1	6	2/1/2020
Nozzle Coverage, Placement, And Aiming	3-1	6	2/1/2020
Duct Protection	3-1	6	2/1/2020
50" (127 cm) Perimeter Maximum Ducts	3-1	6	2/1/2020
150" (381 cm) Perimeter Maximum Ducts	3-1	6	2/1/2020
Ducts Larger than 150" (381 cm) Perimeter	3-2	6	2/1/2020
Transition Ducts	3-2	6	2/1/2020
Larger to Smaller Duct Transitions	3-2	6	2/1/2020
Smaller to Larger Duct Transitions	3-2	6	2/1/2020
Upper / Lower Plenums	3-2	6	2/1/2020
Electrostatic Precipitators	3-2	6	2/1/2020
Plenum Protection	3-3	6	2/1/2020
Plenum: V-bank Nozzle Placement	3-3	6	2/1/2020
Plenum: Single Filter Bank Nozzle Placement	3-3	6	2/1/2020
Appliance Protection	3-3	6	2/1/2020
Design Terminology	3-3	6	2/1/2020
Appliances Requiring Multiple Nozzles	3-3	6	2/1/2020
Range Protection	3-3	6	2/1/2020

<u>SECTION/SUBJECT</u>	<u>Page</u>	<u>Rev</u>	<u>Date</u>
Two (2) Burner Range – Low Proximity	3-3	6	2/1/2020
Four (4) Burner Range – HIGH Proximity	3-4	6	2/1/2020
Four (4) Burner Range – LOW Proximity	3-4	6	2/1/2020
Six (6) Burner Range	3-4	6	2/1/2020
Range / Griddle Combination Appliance	3-5	6	2/1/2020
Protection for Appliances with a Back-shelf	3-5	6	2/1/2020
Four Burner Range with Back-shelf – HIGH Proximity	3-6	6	2/1/2020
Wok Protection	3-6	6	2/1/2020
Deep Fat Fryer Protection	3-7	6	2/1/2020
Fryers Requiring Multiple Nozzles	3-7	6	2/1/2020
Tilting Brazing Skillet Protection	3-7	6	2/1/2020
Griddle Protection	3-7	6	2/1/2020
Standard Griddle: 42" (107 cm) x 30" (76 cm)	3-7	6	2/1/2020
Large Griddle - 48" (122 cm) x 30" (76 cm)	3-8	6	2/1/2020
Extra Large Griddle: 60" (152 cm) x 30" (76 cm)	3-8	6	2/1/2020
Extra Low Proximity Griddle	3-9	6	2/1/2020
Low Proximity Griddle	3-9	6	2/1/2020
Charbroiler Protection	3-9	6	2/1/2020
Radiant Charbroiler	3-9	6	2/1/2020
Lava Rock Charbroiler	3-10	6	2/1/2020
Upright Broiler	3-10	6	2/1/2020
Appliances Requiring Multiple Nozzles (Module Protection)	3-11	6	2/1/2020
Coverage Summary Table	3-12	6	2/1/2020
Piping Limitations	3-13	6	2/1/2020
Piping Volume Chart	3-13	6	2/1/2020
Maximum Piping Per Cylinder Size Chart	3-13	6	2/1/2020
Minimum Piping Requirements	3-13	6	2/1/2020



TABLE OF CONTENTS

<u>SECTION/SUBJECT</u>	<u>Page</u>	<u>Rev</u>	<u>Date</u>
General Piping Requirements	3-13	6	2/1/2020
Detector Placement	3-14	6	2/1/2020
Exhaust Duct Detector Placement	3-14	6	2/1/2020
Cooking Appliance Detector Placement	3-14	6	2/1/2020
Chapter 4, System Installation			
General	4-1	6	2/1/2020
Cylinder Installation	4-1	6	2/1/2020
Pipe and Nozzle Installation	4-1	6	2/1/2020
Systems Releasing Module(s) Installation	4-2	6	2/1/2020
Mounting Systems Releasing Module(s) Directly to Cylinder Valve	4-2	6	2/1/2020
Wall Mounting of Systems Releasing Module(s)	4-2	6	2/1/2020
Wall Mounting, Actuating Only One Agent Cylinder Remotely	4-2	6	2/1/2020
Limitations for Remote Cylinder Actuation	4-3	6	2/1/2020
Wall Mounting, Actuating Multiple Agent Cylinders Remotely	4-3	6	2/1/2020
Buckeye Shielded Cable Installation Overview	4-4	6	2/1/2020
Overview	4-4	6	2/1/2020
Buckeye Shielded Cable Installation Guidelines	4-5	6	2/1/2020
Minimum Bend Radius	4-5	6	2/1/2020
Buckeye Shielded Cable Interface Installation	4-6	6	2/1/2020
Fusible Link Line Installation Overview	4-7	6	2/1/2020
Method #1: Buckeye Shielded Cable, No Conduit	4-7	6	2/1/2020
Method #2: Buckeye Shielded Cable with Conduit	4-7	6	2/1/2020
Method #3: Conduit Outside Plenum, No Conduit in Plenum	4-8	6	2/1/2020

<u>SECTION/SUBJECT</u>	<u>Page</u>	<u>Rev</u>	<u>Date</u>
Method #4: Conduit Outside Plenum, Conduit in Plenum	4-8	6	2/1/2020
Method #5: Combination, BSC and Conduit, No Conduit in Plenum	4-9	6	2/1/2020
Method #6: Combination, BSC and Conduit, Conduit in Plenum	4-9	6	2/1/2020
Fusible Link Line Installation	4-10	6	2/1/2020
Fusible Link Line Limitations	4-10	6	2/1/2020
Fusible Link Line Installation	4-10	6	2/1/2020
Brackets and Conduit in Plenum Area	4-10	6	2/1/2020
No Brackets and Conduit in Plenum Area	4-10	6	2/1/2020
Connecting Plenum Area to SRM, Conduit and Corner Pulleys	4-11	6	2/1/2020
Connecting Plenum Area to SRM, Buckeye Shielded Cable Only	4-11	6	2/1/2020
Connecting Plenum Area to SRM, Combination of Conduit and Buckeye Shielded Cable	4-11	6	2/1/2020
Fusible Link Installation in Plenum Area	4-12	6	2/1/2020
Using Fusible Link Brackets and Conduit	4-12	6	2/1/2020
Using Fusible Link Holders with Brackets	4-12	6	2/1/2020
When Fusible Link Brackets and Conduit Are Not Used	4-13	6	2/1/2020
Using Fusible Link Holders without Brackets	4-13	6	2/1/2020
Remote Pull Station Installation	4-14	6	2/1/2020
Remote Pull Station Limitations	4-14	6	2/1/2020
Model RPS-M Mounting	4-14	6	2/1/2020
Model RPS-M Installation	4-14	6	2/1/2020
Model RPS-M-RM (Recessed) Mounting and Installation	4-15	6	2/1/2020
Mechanical Gas Valve Installation	4-17	6	2/1/2020

TABLE OF CONTENTS



<u>SECTION/SUBJECT</u>	<u>Page</u>	<u>Rev</u>	<u>Date</u>
Mechanical Gas Valve Limitations	4-17	6	2/1/2020
Setting the Systems Release Module(s)	4-18	6	2/1/2020
Setting the Systems Release Module(s) - Mechanical	4-18	6	2/1/2020
Model SRM2-M	4-18	6	2/1/2020
Connecting the Remote Pull Station Cable	4-18	6	2/1/2020
Connecting the Fusible Link Line	4-18	6	2/1/2020
Applying Tension to the Fusible Link Line	4-18	6	2/1/2020
Setting the SRM2-M	4-19	6	2/1/2020
Proper Method of Releasing Fusible Link Line Tension	4-20	6	2/1/2020
Setting the Mechanical Gas Valve	4-20	6	2/1/2020
Model SRM	4-21	6	2/1/2020
Connecting the Remote Pull Station Cable	4-21	6	2/1/2020
Connecting the Fusible Link Line	4-21	6	2/1/2020
Applying Tension to the Fusible Link Line	4-22	6	2/1/2020
Before Setting the Systems Releasing Module(s)	4-23	6	2/1/2020
Setting the SRM	4-23	6	2/1/2020
Setting the Mechanical Gas Valve	4-23	6	2/1/2020
Model SRM-D	4-24	6	2/1/2020
Connecting the Remote Pull Station Cable	4-24	6	2/1/2020
Setting the SRM-D	4-24	6	2/1/2020
Connecting and Setting Optional Secondary Detection Line	4-24	6	2/1/2020
Setting the Mechanical Gas Valve (SRM-D Only)	4-25	6	2/1/2020

<u>SECTION/SUBJECT</u>	<u>Page</u>	<u>Rev</u>	<u>Date</u>
Setting the Systems Release Module(s) - Electrical	4-26	6	2/1/2020
Model SRM2-E-24 and SRM2-E-120	4-26	6	2/1/2020
Connecting the Remote Pull Station Cable	4-26	6	2/1/2020
Install Electrical Thermal Detectors	4-26	6	2/1/2020
Install Solenoid Monitor	4-26	6	2/1/2020
Solenoid Monitor Mounting	4-26	6	2/1/2020
Connecting the Detection/Actuation Circuit	4-26	6	2/1/2020
Setting the SRM2-E-24/120	4-28	6	2/1/2020
Setting the Mechanical Gas Valve	4-28	6	2/1/2020
Energizing the Circuit	4-28	6	2/1/2020
Solenoid Monitor When Used as a Reset Relay	4-29	6	2/1/2020
Setting the Mechanical Gas Valve	4-30	6	2/1/2020
Installing Nitrogen Actuation Cartridge	4-31	6	2/1/2020
Installing SRM Cover Plate	4-32	6	2/1/2020
System Checkout After Installation	4-33	6	2/1/2020
Mechanical Systems Releasing Module(s) (Models SRM, SRM-D and SRM2-M)	4-33	6	2/1/2020
Electrical Systems Releasing Module(s) (Models SRM2-E-24 and SRM2-E-120)	4-34	6	2/1/2020
Putting the System into Operation	4-35	6	2/1/2020
Chapter 5, System Inspection and Maintenance			
Maintenance Overview	5-1	6	2/1/2020
Owners Inspection – Monthly	5-1	6	2/1/2020
Semi-Annual Maintenance	5-1	6	2/1/2020
Annual Maintenance	5-2	6	2/1/2020



TABLE OF CONTENTS

Page i - 5
Revision 6

<u>SECTION/SUBJECT</u>	<u>Page</u>	<u>Rev</u>	<u>Date</u>
Twelve (12) Year Maintenance	5-4	6	2/1/2020
Chapter 6, System Recharge			
Overview	6-1	6	2/1/2020
Valve Rebuilding Components	6-1	6	2/1/2020
Valve Rebuilding Kit (Model BFR-VRK)	6-1	6	2/1/2020
Valve Rebuild Tool (Model BFR-VRT)	6-1	6	2/1/2020
System Recharge	6-1	6	2/1/2020
Recharge Agent Quantities Required	6-2	6	2/1/2020
Appendix A			
Material Safety Data Sheet	A-1	6	2/1/2020



This Page Intentionally Blank.



INDEX OF FIGURES

<u>Figure No.</u>	<u>Description</u>	<u>Page</u>	<u>Rev</u>	<u>Date</u>
2-1	Cylinder and Valve Assembly Dimensions and Table	2-1	6	2/1/2020
2-2	Model BFR-VLV Valve Assembly	2-2	6	2/1/2020
2-3	Model BFR-CAP Valve Cap Assembly	2-2	6	2/1/2020
2-4	Model BFR-DAK Discharge Adaptor Kit	2-2	6	2/1/2020
2-5	Model SRM2-M Mechanical System Releasing Module	2-3	6	2/1/2020
2-6	Model SRM-D Systems Releasing Module	2-3	6	2/1/2020
2-7	Model SRM Systems Releasing Module	2-3	6	2/1/2020
2-8	Model SRM2-E-24 Electric (24 VDC) Releasing Module	2-4	6	2/1/2020
2-9	Model SRM-E-120 Electric (120 VAC) Releasing Module	2-4	6	2/1/2020
2-10	Systems Releasing Module(s) Overall Dimensions	2-5	6	2/1/2020
2-11	SM-120 Solenoid Monitoring Panel	2-5	6	2/1/2020
2-12	Model MS-DPDT Miniature Electrical (Micro-Switch-DPDT) Switch	2-5	6	2/1/2020
2-13	DPDT Writing Diagram (SRM2-M Shown)	2-6	6	2/1/2020
2-14	Model MS-AIS Alarm Initiating Micro Switch	2-6	6	2/1/2020
2-15	Globe ML Fusible Link	2-6	6	2/1/2020
2-16	Thermal Detector	2-6	6	2/1/2020
2-17	Model BFR-AC-S and BFR-AC-L Nitrogen Actuation Cartridges	2-7	6	2/1/2020
2-18	Model MB-1 Shown With BFR-5 Cylinder	2-7	6	2/1/2020
2-19	Model MB-2 Shown with BFR-20 Cylinder	2-7	6	2/1/2020
2-20	Model RPS-M Remote Mechanical Pull Station	2-7	6	2/1/2020
2-21	Model RPS-M-RM Remote Mechanical Pull Station-Recessed Mount	2-8	6	2/1/2020

<u>Figure No.</u>	<u>Description</u>	<u>Page</u>	<u>Rev</u>	<u>Date</u>
2-22	Model BFGV_XXX Mechanical Gas Valve	2-8	6	2/1/2020
2-23	Model FLB-1 10" (25cm) Fusible Link Bracket Assembly	2-8	6	2/1/2020
2-24	Model FLH Fusible Link Holder	2-8	6	2/1/2020
2-25	Model BFR-SC-100 Buckeye Shielded Cable	2-9	6	2/1/2020
2-26	Model BFR-SCI Shielded Cable Interface	2-9	6	2/1/2020
2-27	Model CPCT-1 Compression Type Corner Pulley	2-9	6	2/1/2020
2-28	Discharge Nozzle	2-9	6	2/1/2020
2-29	Model N-SA Swivel Adaptor	2-9	6	2/1/2020
3-1	Proper Duct Nozzle Placement	3-1	6	2/1/2020
3-2	Proper Duct Nozzle Placement	3-2	6	2/1/2020
3-3	Proper measurement and nozzle placement for larger to smaller transition ducts.	3-2	6	2/1/2020
3-4	Proper measurement and nozzle placement for smaller to larger transition ducts.	3-2	6	2/1/2020
3-5	Upper / Lower Plenum Protection	3-2	6	2/1/2020
3-6	Electrostatic Precipitator Protection.	3-2	6	2/1/2020
3-7	Model N-1HP Plenum Nozzle Placement and Aiming	3-3	6	2/1/2020
3-8	Low Proximity 12" (30.5 cm) x 24" (61 cm) Range, Model N-1LP Nozzle	3-4	6	2/1/2020
3-9	High Proximity 24" (61 cm) x 24" (61 cm) Range, Model N-1LP Nozzle	3-4	6	2/1/2020
3-10	Low Proximity 24" (61 cm) x 24" (61 cm) Range, Model N-2W Nozzle	3-4	6	2/1/2020
3-11	36" (91 cm) x 24" (61 cm) Range, Model N-2LP Nozzle	3-5	6	2/1/2020

INDEX OF FIGURES



Figure No.	Description	Page	Rev	Date
3-12	30" (76 cm) x 24" (24 cm) Combination Range/Griddle, Model N-1LP Nozzle	3-5	6	2/1/2020
3-13	24" (61cm) x 24" (61 cm) Four Burner Range with Back-shelf, Model N-2W Nozzle	3-5	6	2/1/2020
3-14	12" (30.5 cm) x 24" (61 cm) Two Burner Range with Back-shelf, Model N-1LP Nozzle	3-5	6	2/1/2020
3-14a	24" (61cm) x 24" (61 cm) Range with Back Shelf, Model N-2LP Nozzle	3-6	6	2/1/2020
3-14b	Wok Protection, Model N-1HP Nozzle	3-6	6	2/1/2020
3-15	20.25" (51 cm) x 24" (61 cm) Deep Fat Fryer, Model N-2hp Nozzle	3-7	6	2/1/2020
3-16	Tilting Skillet / Brazing Pan, Model N-2HP Nozzle	3-7	6	2/1/2020
3-17	Standard Griddle: 42" (107 cm) x 30" (76 cm), Model N-1LP Nozzle	3-8	6	2/1/2020
3-18	Large Griddle: 48" (122 cm) x 30" (76 cm), Model N-1LP Nozzle	3-8	6	2/1/2020
3-19	Extra Large Griddle: 60" (152 cm) x 30" (76 cm), Model N-2LP Nozzle	3-8	6	2/1/2020
3-19a	42" (107 cm) x 30" (76 cm) Griddle, Model N-2W Nozzle	3-9	6	2/1/2020
3-19b	60" (152 cm) x 30" (76 cm) Griddle, Model N-2W Nozzle	3-9	6	2/1/2020
3-20	Radiant Charbroiler, Model N-1HP Nozzle	3-10	6	2/1/2020
3-21	Lava Rock Charbroiler, Model N-2HP Nozzle	3-10	6	2/1/2020
3-22	Upright Broiler 36" (91 cm) x 24" (61 cm) Model N-1LP Nozzle	3-11	6	2/1/2020
3-24	Sample Radiant Charbroiler Module Protection	3-11	6	2/1/2020
3-26	Proper Detector Placement Appliances and Duct	3-14	6	2/1/2020
4-1	Cylinder and Mounting Bracket Installation	4-1	6	2/1/2020
4-2	Systems Releasing Module(s) Mounted Directly to Cylinder Valve (Model SRM Shown)	4-2	6	2/1/2020
4-3	Systems Releasing Module(s) Shown Actuating a Single Agent Cylinder (Model SRM Shown)	4-3	6	2/1/2020

Figure No.	Description	Page	Rev	Date
4-4	Multiple Cylinder Actuation Using the Systems Releasing Module(s)	4-3	6	2/1/2020
4-5	Buckeye Shielded Cable Installation Typical Installation	4-4	6	2/1/2020
4-6	Buckeye Shielded Cable	4-5	6	2/1/2020
4-7	Cutting Buckeye Shielded Cable	4-5	6	2/1/2020
4-8	Buckeye Shielded Cable Minimum Bend Radius	4-6	6	2/1/2020
4-9	Buckeye Shielded Cable Interface Installation Detail	4-6	6	2/1/2020
4-10	Buckeye Shielded Cable Interface Typical Connection Types	4-6	6	2/1/2020
4-11	Fusible Link Line Installation Method #1	4-7	6	2/1/2020
4-12	Fusible Link Line Installation Method #2	4-7	6	2/1/2020
4-13	Fusible Link Line Installation Method #3	4-8	6	2/1/2020
4-14	Fusible Link Line Installation Method #4	4-8	6	2/1/2020
4-15	Fusible Link Line Installation Method #5	4-9	6	2/1/2020
4-16	Fusible Link Line Installation Method #6	4-9	6	2/1/2020
4-17	Terminal Bracket Installation for Systems Without Brackets or Conduit In Plenum Area	4-11	6	2/1/2020
4-18	Installation of Terminal Bracket	4-12	6	2/1/2020
4-19	Series Link Installation	4-12	6	2/1/2020
4-20	Terminal Bracket Connection	4-12	6	2/1/2020
4-21	Fusible Link Connection	4-12	6	2/1/2020
4-22	Fusible Link Holder Connection	4-13	6	2/1/2020
4-23	Fusible Link Line Termination in Plenum	4-13	6	2/1/2020



INDEX OF FIGURES

Figure No.	Description	Page	Rev	Date
4-24	Fusible Link Connection	4-13	6	2/1/2020
4-25	Typical Fusible Link Installation	4-13	6	2/1/2020
4-26	Fusible Link Line Installation	4-14	6	2/1/2020
4-27	Remote Pull Station Installation	4-15	6	2/1/2020
4-28	Recessed Mount Remote Pull Station Installation	4-15	6	2/1/2020
4-29	Recessed Mount Remote Pull Station Installation	4-16	6	2/1/2020
4-30	Gas Valve Installation	4-17	6	2/1/2020
4-31	Connecting the RPS-M Cable to the SRM2-M	4-18	6	2/1/2020
4-32	Connecting Fusible Link Line to The SRM2-M	4-18	6	2/1/2020
4-33	Methods of Connecting Fusible Link Line to Fusible Link Line Ratchet	4-19	6	2/1/2020
4-34	Remove Slack from Fusible Link Line	4-19	6	2/1/2020
4-35	Tensioning Fusible Link Line	4-19	6	2/1/2020
4-36	SET Position of Detection Slide Plate	4-19	6	2/1/2020
4-37	Setting Trigger and Actuation Arms	4-20	6	2/1/2020
4-38	Trigger Arm SET Actuation Arm Now Engaged	4-20	6	2/1/2020
4-39	Releasing Tension in The Fusible Link Line	4-20	6	2/1/2020
4-40	Mechanical Pull Station Cable Connection	4-21	6	2/1/2020
4-41	Two Methods of Connecting Fusible Link Line to Fusible Link Ratchet	4-21	6	2/1/2020
4-42	Connecting Fusible Link Line to Systems Releasing Module	4-21	6	2/1/2020
4-43	Catch In "SET" Position	4-22	6	2/1/2020
4-44	Applying Tension to The Fusible Link Line	4-22	6	2/1/2020
4-45	Fusible Link in SET Position	4-22	6	2/1/2020
4-46	Removing Additional Slack	4-22	6	2/1/2020

Figure No.	Description	Page	Rev	Date
4-47	Locate 3/16" (0.5 cm) Hex Head Socket	4-23	6	2/1/2020
4-48	Setting Detection Trigger	4-23	6	2/1/2020
4-49	Systems Releasing Module Shown in SET Position	4-23	6	2/1/2020
4-50	Mechanical Pull Station Cable Connection to the SRM-D	4-24	6	2/1/2020
4-51	Primary Fusible Link Line SET Systems Releasing Module-Dual	4-24	6	2/1/2020
4-52	Securing Primary Fusible Link Line	4-24	6	2/1/2020
4-53	Setting Secondary Detection Trigger	4-25	6	2/1/2020
4-54	SRM-D Gas Valve Ratchet and Cable	4-25	6	2/1/2020
4-55	Applying Tension to the SRM-D Mechanical Gas Valve Cable	4-25	6	2/1/2020
4-56	Mechanical Gas Valve In "SET" Position	4-25	6	2/1/2020
4-57	Connecting the RPS-M Cable to the SRM2-E	4-26	6	2/1/2020
4-58	Mounting of The Solenoid Monitor	4-26	6	2/1/2020
4-59	Model SRM-E-24/120 Systems Releasing Module Wiring Schematic	4-27	6	2/1/2020
4-60	Detector Connection Point	4-27	6	2/1/2020
4-61	Setting the Model SRM2-E-24/120	4-28	6	2/1/2020
4-62	Model SRM-E-24/120 , SET Solenoid Shutoff Switch Engaged	4-28	6	2/1/2020
4-63	Solenoid Monitor	4-29	6	2/1/2020
4-64	Electrical SRM2-E-24/120 Wiring Schematic	4-29	6	2/1/2020
4-65	Mechanical Gas Valve Connection and Ratchet	4-30	6	2/1/2020
4-66	Applying Tension to the Mechanical Gas Valve Cable	4-30	6	2/1/2020
4-67	Mechanical Gas Valve In "SET" Position	4-30	6	2/1/2020
4-68	Setting Actuation Pin	4-31	6	2/1/2020
4-69	Installing Nitrogen Cartridge	4-31	6	2/1/2020
4-70	Dating Nitrogen Cartridge	4-31	6	2/1/2020

INDEX OF FIGURES

Page ii - 4
Revision 6



<u>Figure No.</u>	<u>Description</u>	<u>Page</u>	<u>Rev</u>	<u>Date</u>
4-71	Installing Systems Releasing Module(s) Cover	4-32	6	2/1/2020
6-1	Model BFR-VRK Valve Rebuilding Kit	6-1	6	2/1/2020
6-2	Model BFR-VRT, Valve Rebuilding Tool	6-1	6	2/1/2020



Chapter 1

General Information

Introduction

The Buckeye Fire Equipment *Kitchen Mister* Fire Suppression System is a pre-engineered wet chemical restaurant fire suppression system as defined by the NFPA-17A Standard for Wet Chemical Extinguishing Systems. It is designed to protect commercial restaurant cooking appliances, hoods, and ducts as described in this manual.

Installation and maintenance of the *Kitchen Mister* System must be in compliance with the parameters set forth in this manual and be performed by a factory trained, Authorized Buckeye Fire Equipment Distributor.

CAUTION

This technical manual can in no way be considered sufficient to completely understand the proper design, installation, and/or maintenance of the *Kitchen Mister* System. Buckeye Certified Training is required to become Authorized to perform these procedures. Buckeye Fire Equipment will not be responsible for system(s) designed, installed, or maintained by individuals or companies not trained and Authorized by Buckeye Fire Equipment.

How the Kitchen Mister Works

The *Kitchen Mister* System utilizes a potassium based liquid fire extinguishing agent specifically designed for grease laden fires such as those associated with restaurant cooking areas. The *Kitchen Mister* agent works to suppress commercial kitchen fires in three ways:

1. The agent interrupts the chemical chain reaction causing combustion, thus extinguishing the fire.
2. The agent is discharged in a very fine mist, cooling the fire to below its auto-ignition temperature.
3. The agent reacts with grease to form a foam-like layer commonly called saponification that starves the fire of oxygen, stopping combustion and preventing re-ignition.

The system will automatically actuate upon detection of a fire or can be manually actuated by using a remote manual pull station positioned at the point(s) of egress from the hazard area. When the system is actuated, a pre-determined amount of fire extinguishing agent is discharged through the piping network and fixed nozzles to the duct, plenum, and cooking appliances. The agent is discharged as a very fine mist that quickly acts to suppress grease laden fires.

System Temperature Limitations

The operating temperature range of the *Kitchen Mister* System is 32°F (0°C.) minimum to 120°F (49°C.) maximum.

Listings and Approvals

The *Kitchen Mister* Fire Suppression System is Listed and Approved by the following agencies:

- Underwriters Laboratories, Inc. (Listed to the requirements of UL-300/UL-1254) UL-EX 6885
- Underwriters Laboratories of Canada, ULC-EX 6885
- Approved by the New York City Fire Department COA # 5550
- ISO-9001 Registered

Manufacturer's Warranty

Buckeye Fire Equipment warrants the *Kitchen Mister* System against defects in material and workmanship for a period of one year from date of shipment to the purchaser under normal use and service. Buckeye Fire Equipment is not responsible for the installation and maintenance of the system. All warranty claims must be filed with Buckeye Fire Equipment within 30 days of the discovery of the defect to be valid.

System Installation and Maintenance Requirements

Any individual installing or performing maintenance on the *Kitchen Mister* System **MUST** be; fully trained and Authorized by Buckeye Fire Equipment, have a complete understanding of this manual in full, and have a complete understanding of all local, state, and federal requirements that may apply. The Buckeye *Kitchen Mister* System must be installed and maintained in accordance with the NFPA-17A Standard for Wet Chemical Extinguishing Systems, NFPA-96 Standard for Ventilation Control and Fire Protection of Commercial Cooking Operations, this manual, and all applicable local, state, and federal regulations.

Buckeye Fire Equipment is not responsible for systems installed or maintained by personnel that are not factory trained and Authorized.



This Page Intentionally Blank.



Chapter 2 System Components

Cylinder Sizes

The Buckeye Fire Equipment *Kitchen Mister* Fire Suppression System has available four (4) cylinder sizes; the **Model BFR-5** (5 flow points), **Model BFR-10** (10 flow points), **Model BFR-15** (15 flow points), and **Model BFR-20** (20 flow points). Cylinder sizes are based on the flow point capacity of the cylinder, for example, the BFR-5 is capable of supporting a maximum of five (5) flow points. All cylinders are manufactured, marked, and tested in accordance with DOT 4BW240. Each cylinder is shipped pre-filled with extinguishing agent and charged with dry nitrogen to a pressure of 195 psig (1344 KPa) @ 70° F (21° C). Cylinder and valve assembly dimensions are shown in **Figure 2-1**.

Note: Cylinders shall always be stored and installed in an upright position.

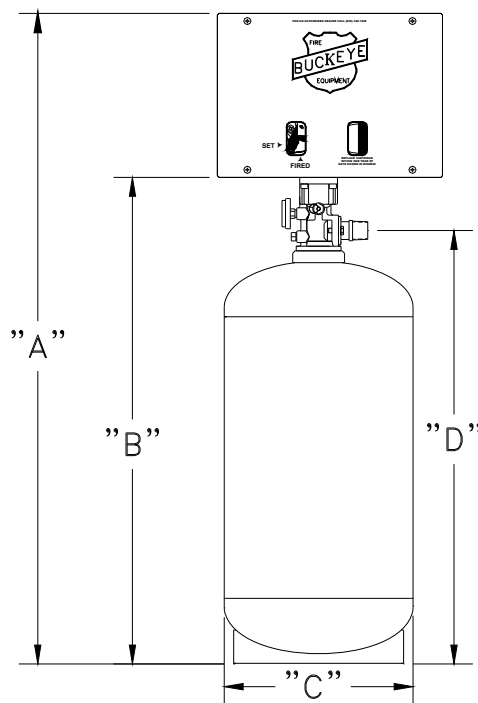

Figure 2-1.
Cylinder and Valve Assembly Dimensions.

Model Number	A inches (cm)	B inches (cm)	C inches (cm)	D inches (cm)	Max. Flow Points	Weight lbs. (kg)	Mounting Bracket
BFR-5	24.8 (63)	16.2 (41)	10 (25)	13.4 (34)	5	42 lbs. (19)	MB-1
BFR-10	34.4 (87)	25.8 (66)	10 (25)	23 (58)	10	74 lbs. (33)	MB-2
BFR-15	44.8 (114)	36.2 (92)	10 (25)	33.4 (85)	15	107 lbs. (48)	MB-2
BFR-20	42.4 (108)	33.8 (86)	12 (31)	31 (79)	20	130 lbs. (60)	MB-2



Valve Assembly

All Kitchen Mister System cylinders utilize the same poppet style valve assembly, the **Model BFR-VLV** as shown in **Figure 2-2**.

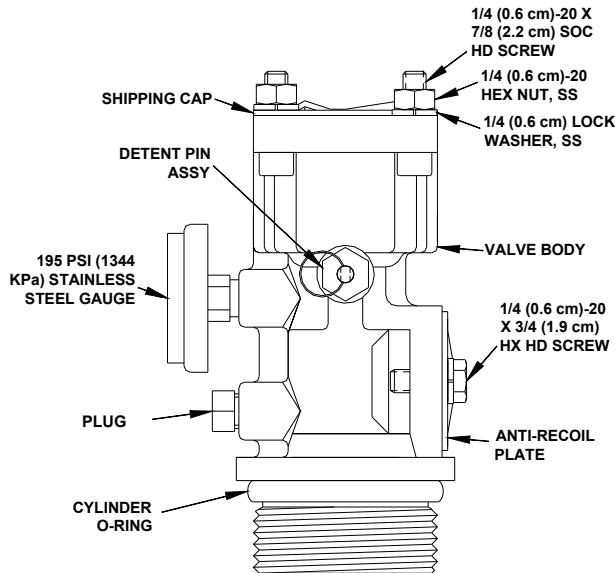

Figure 2-2.
Model BFR-VLV,
Valve Assembly

The valve comes equipped with a detent pin that will, upon system actuation, lock the valve in the open position assuring full discharge of the extinguishing agent. To reset the valve after actuation, simply pull the ring on the detent pin and the valve stem will return to its closed position.

Valve Cap Assembly

The **Model BFR-CAP** Valve Cap Assembly is required for remote or multi-cylinder actuation. It is used to connect the Systems Releasing Module(s) to the cylinder valve using 1/4" (0.6 cm) copper tubing. See **Figure 2-3**.

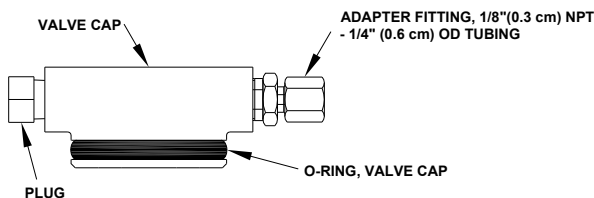

Figure 2-3.
Model BFR-CAP,
Valve Cap Assembly

Discharge Adaptor Kit

The **Model BFR-DAK** Discharge Adaptor Kit is included with all Buckeye cylinders and is required to connect the cylinder valve assembly to the discharge piping. See **Figure 2-4**.

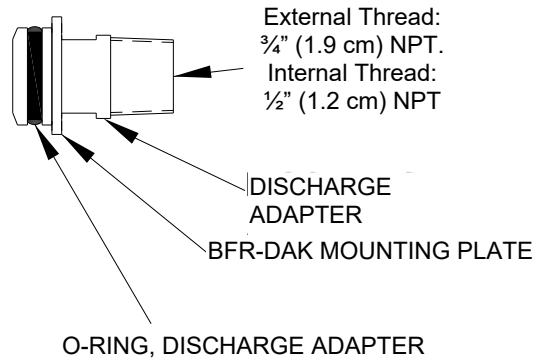

Figure 2-4.
Model BFR-DAK,
Discharge Adaptor Kit

Extinguishing Agent

The Kitchen Mister System utilizes a potassium carbonate based extinguishing agent that is specifically designed to extinguish grease laden fires such as those found in commercial cooking areas. The recharge agent is available in two different sized containers; the **Model BFR-5R** (5 flow points of agent) and the **Model BFR-10R** (10 flow points of agent). For information on the proper procedure for refilling the cylinder after system discharge, refer to **Chapter 5** of this manual.

WARNING

Goggles must be worn at all times when handling extinguishing agent because it is very caustic in nature. If agent gets in eyes, they must be flushed with clear water for at least 15 minutes and a physician contacted. If agent contacts skin, it should be washed with cold water to prevent irritation. When cleaning up agent discharged around electrical devices or appliances, make sure the power is off before proceeding with cleanup. The agent is electrically conductive.



Systems Releasing Modules

Systems Releasing Modules - Mechanical

Model SRM2-M

The **Model SRM2-M** Systems Releasing Module - Mechanical is a fully mechanical control head that can be used for system actuation. The **Model SRM2-M** can be connected directly to the cylinder valve or remotely to the system valve(s). The **Model SRM2-M** will support the following system inputs and outputs:

- One (1) Fusible Link Detection Line
- Mechanical Gas Valve(s)
- Mechanical Remote Pull Station(s)
- Up to four (4) sets of dry contacts

Two windows in the front cover of the **Model SRM2-M** allow for visual verification of the actuation cartridge and the system status (SET/FIRED). See **Figure 2-5**.

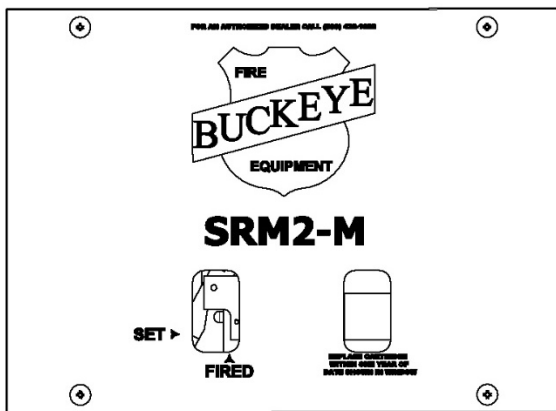

Figure 2-5.
Model SRM2-M,
Mechanical Systems Releasing Module

The **Model SRM2-M** can actuate a maximum of three (3) agent cylinders when using the **Model BFR-AC-S** Nitrogen Activation Cartridge (included with the SRM2-M) or five (5) agent cylinders when a **Model BFR-AC-L** Nitrogen Activation Cartridge is installed.

Model SRM-D

The **Model SRM-D** (Systems Releasing Module –Dual) is the same as the **Model SRM** except that it supports a second independent fusible link detection line. See **Figure 2-6**.

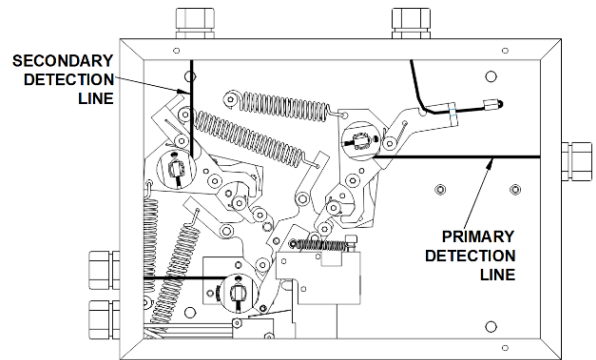

Figure 2-6.
Model SRM-D,
Systems Releasing Module-Dual

Model SRM

The **Model SRM**, Systems Releasing Module is a fully mechanical control head that can be connected directly or remotely to the system valve and is required for system actuation. The Systems Releasing Module will support the following system inputs and outputs:

- One Fusible Link Detection Line
- One Gas Valve Line
- One Remote Pull Station Line
- Up to four (4) sets of dry contacts

Two windows in the front cover of the **Model SRM** allow for visual verification of the actuation cartridge presence and the system status (SET/FIRED). See **Figure 2-7**.

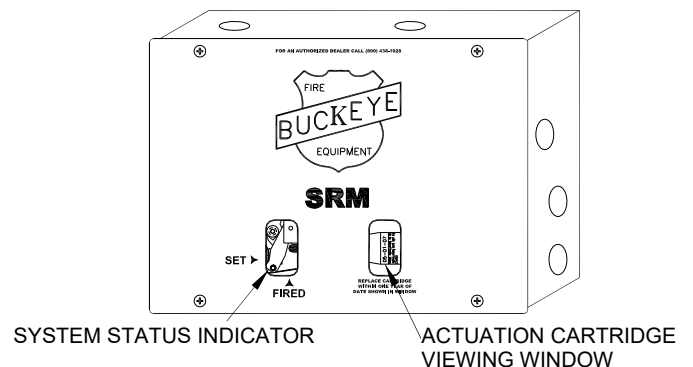

Figure 2-7.
Model SRM,
Systems Releasing Module



The **Model SRM** can actuate a maximum of three (3) agent cylinders when using the **Model BFR-AC-S** Nitrogen Activation Cartridge (included with SRM and SRM-D) or five (5) agent cylinders when a **Model BFR-AC-L** Nitrogen Activation Cartridge is installed.

Systems Releasing Module(s) - Electric

When utilizing electric detection, it is required that the **SRM2-E** be used with a Solenoid Monitor.

If the detection circuit utilizes a 120-volt AC power source, the **Model SRM2-E-120** must be used with a **Model SM-120** Solenoid Monitor along with a UL Listed 1A, 120VAC power supply (by others), in accordance with NFPA 17A, NFPA 96, and the local authority having jurisdiction.

If the detection circuit utilizes a 24 VDC power supply, it is required that the **Model SRM2-E-24** be used with a **Model SM-24** Solenoid Monitor. The **Model SRM2-E-24** requires a 24 VDC power supply with a minimum 2A rating.

Model SRM2-E-24

The **Model SRM2-E-24** Systems Releasing Module – Electric - 24 VDC, is an electrically (24-volt DC) operated control head that can be used for system actuation. The **Model SRM2-E-24** can be connected directly to the cylinder valve or remotely to the system valve(s). The **Model SRM2-E-24** will support the following system inputs and outputs:

- Thermal (Electric) Detection
- Mechanical/Electrical Gas Valve(s)
- Mechanical Remote Pull Station(s)
- Up to four (4) sets of dry contacts

Two windows in the front cover of the **Model SRM2-E-24** allow for visual verification of the actuation cartridge presence and the system status (SET/FIRED). See **Figure 2-8**.

The **Model SRM2-E-24** can actuate a maximum of three (3) agent cylinders when using the **Model BFR-AC-S** Nitrogen Activation Cartridge (included with the SRM2-M) or five (5) agent cylinders when a **Model BFR-AC-L** Nitrogen Activation Cartridge is installed.

Model SRM2-E-120

The **Model SRM2-E-120** Systems Releasing Module – Electric – 120 VAC, is an electrically (120-volt AC/ 60 Hz) operated control head that can be used for system actuation. The **Model SRM2-E-120** can be connected directly to the cylinder valve or remotely to the system valve(s). The **Model SRM2-E-120** will support the following system inputs and outputs:

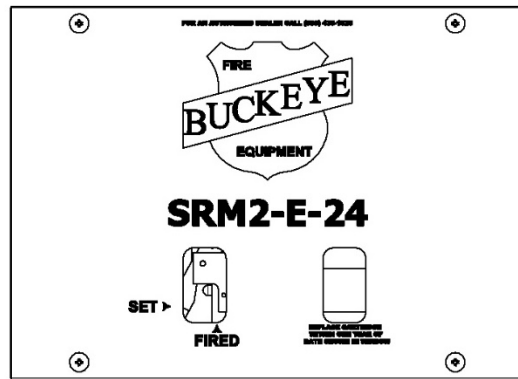

Figure 2-8.
Model SRM2-E-24,
Electric (24 VDC) Releasing Module

- Thermal (Electric) Detection
- Mechanical/Electrical Gas Valve(s)
- Mechanical Remote Pull Station(s)
- Up to four (4) sets of dry contacts

Two windows in the front cover of the **Model SRM2-E-120** allow for visual verification of the actuation cartridge presence and the system status (SET/FIRED). See **Figure 2-9**.

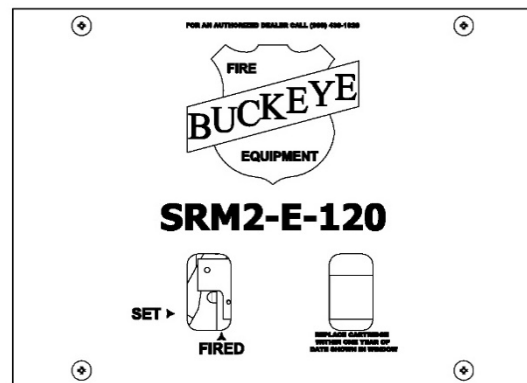

Figure 2-9.
Model SRM2-E-120,
Electric (120 VAC) Releasing Module

The **Model SRM2-M** can actuate a maximum of three (3) agent cylinders when using the **Model BFR-AC-S** Nitrogen Activation Cartridge (included with the SRM2-M) or five (5) agent cylinders when a **Model BFR-AC-L** Nitrogen Activation Cartridge is installed.

All Systems Releasing Modules use the same enclosure and have the same overall dimensions which are given in **Figure 2-10**.

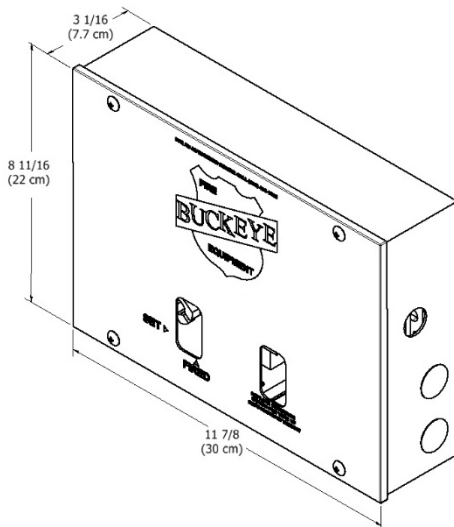

Figure 2-10.
Systems Releasing Module(s) Overall Dimensions

Solenoid Monitor

A solenoid monitor can be used to provide supervision of the actuation and detection circuit. In the event of a problem in the circuit, a light on the Solenoid Monitor will go out, indicating the circuit needs troubleshooting. The solenoid monitor can also provide two (2) sets of NC/NO dry contacts. The panel mounts directly to a deep well three-gang wall outlet box (provided by others). The solenoid monitor can also act as a reset relay when used with an electric gas valve (refer to electric gas valve wiring instructions given in the installation section of this manual).

The solenoid monitor is available in both 120 VAC and 24 VDC voltage configurations. The **Model SM-120** is to be used with 120 AC volt circuits and the **Model SM-24** is for 24 VDC systems. Both panels have the same front panel with the voltage indicated on the back side of the panel. See **Figure 2-11**.

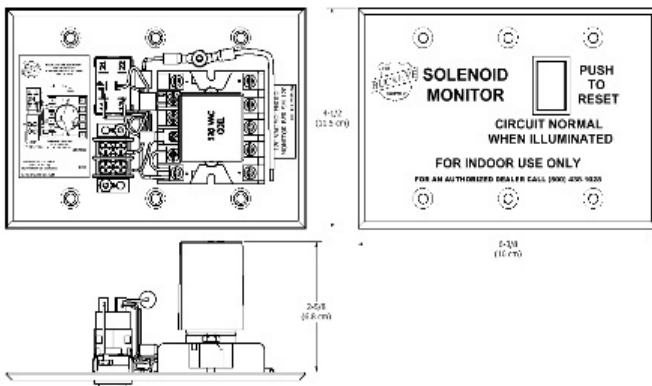

Figure 2-11
SM-120 (Shown Above),
Solenoid Monitoring Panel

Note: If the Solenoid Monitor is used as a reset relay for an electric gas valve, a separate power supply is required to power the electric gas valve.

Microswitches

The Systems Releasing Module(s) comes with two (2) factory installed micro-switches (the same switches as the **Model MS-DPDT**) that are in their normal position when the SRM2 is in the **SET** position. The leads for these switches are approximately two feet long and need to be passed through the bottom left knock-out. See **Figure 2-12 and 2-13**.

NOTE: All electrical connections, unless using the Alarm Initiating Switch (Model MS-AIS), **MUST** be made outside the enclosure in an approved junction box. All applicable electrical codes apply and must be complied with.

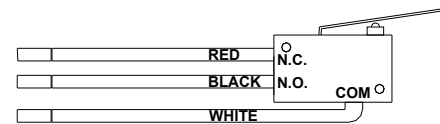

Figure 2-12.
Model MS-DPDT,
Miniature Electrical (Micro Switch-DPDT) Switch

The **Model MS-DPDT** is a field installed set of miniature electrical switches that provides two additional electrical dry connections if they are required. These switches are designed to shut off or turn on when the system is actuated. The **Model MS-DPDT** has two sets of contacts rated at 20.5 125/250 VAC, 1 1/2 HP at 250 VAC, 1/2 HP at 125 VAC each. See **Figure 2-12 and Figure 2-13**.

NOTE: Field installed switches on the front of the manifold block operate the opposite of the factory installed switches. (i.e. when the Systems Releasing Module(s) are in the Set position the normally closed contacts are held open, and the normally open contacts are held closed).

Model MS-AIS Miniature Switches

The **Model MS-AIS** Alarm Initiating Switch allows the connection of an alarm initiating circuit as per NFPA 72 “National Fire Alarm Code”. This switch is to be field installed by trained Buckeye Certified distributors. The switch can be installed on the front of the Manifold Block. Refer to installation instructions supplied with the switch kit for installation details. See **Figure 2-14**.

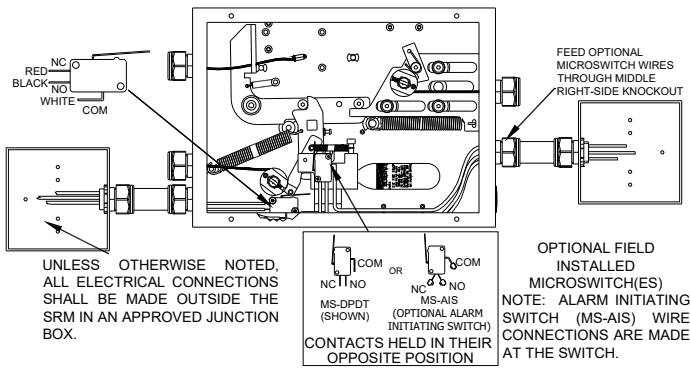

Figure 2-13.
DPDT Wiring Diagram (SRM2-M Shown)

UL/cUL/CSA Rating
5 GPA 125/250 VAC
0.1 GPA 125/250 VAC
1/10 HP 125/250 VAC
0.1 RA 48 VDC

ENEC Rating
0.1 A 125/250 VAC;
0.1 A 48 VDC
5 (2.5) A 125/250 VAC

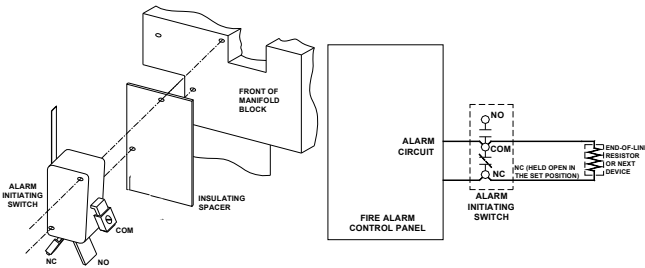

Figure 2-14
Model MS-AIS,
Alarm Initiating Micro Switch

NOTE: All electrical connections unless using the Alarm Initiating Switch (MS-AIS) MUST be made outside the SRM2 enclosure in an approved junction box. All applicable electrical codes apply and must be complied with.

Fusible Links

The *Kitchen Mister* System uses Globe ML Fusible Links for automatic mechanical system activation. See **Figure 2-15**.

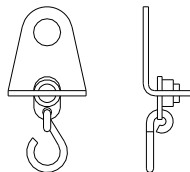

Figure 2-15.
Globe ML Fusible Link

Fusible links are designed to separate at specific temperature, releasing tension from the fusible link

detection line and causing system actuation. Correct fusible link selection is an essential element in the design of any restaurant fire suppression system. After performing a temperature study to determine the maximum ambient temperature at the fusible link location, the correct fusible link should be selected from the following chart:

Fusible Link Model Number	Max. Ambient Temperature
FL-280	225° F. (107° C.)
FL-360	300° F. (149° C.)
FL-450 *	375° F. (191° C.)
FL-500 *	430° F. (221° C.)

* FL-450 and FL-500 fusible links are not approved for use in LPCB certified installation.

Thermal Detectors

Rate-compensating thermal detectors are normally open mechanical contact closure switches designed to operate at a factory preset temperature.

They are available in four (4) preset temperatures which meet NFPA standards and are UL Listed. After determining the maximum ambient temperature at the thermal detector location, select the correct thermal detector according to the temperature condition chart below: See **Figure 2-16**.

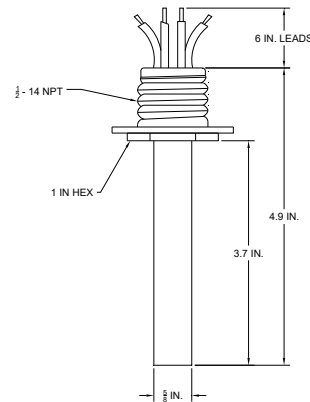

Thermal Detector Model Number	Max. Ambient Temperature
TD-225	155° F (68° C)
TD-325	255° F (124° C)
TD-450	380° F (193° C)
TD-500	430° F (260° C)

Figure 2-16.
Thermal Detector

Note: With a rate-compensating detector a rapid rise of temperature greater than 40° F (4° C) per minute may also initiate an alarm condition.



Nitrogen Actuation Cartridges

The *Kitchen Mister* System can use two types of actuation cartridges for system actuation.

Model BFR-AC-S is a small nitrogen cartridge (included with Systems Releasing Module(s)) that can actuate up to three (3) agent cylinders.

Model BFR-AC-L is a larger nitrogen cartridge that can actuate up to five agent cylinders (refer to **Chapter 4** of this manual for limitations). See **Figure 2-17**.

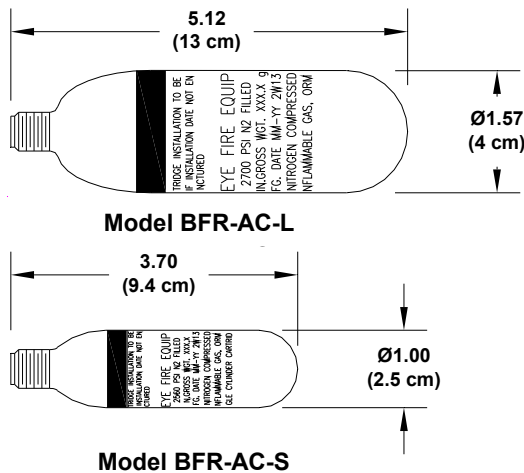

Figure 2-17.
Model BFR-AC-S and BFR-AC-L,
Nitrogen Actuation Cartridges

Mounting Brackets

The **Model MB-1** Mounting Bracket is used to mount the **Model BFR-5** cylinder. See **Figure 2-18**.

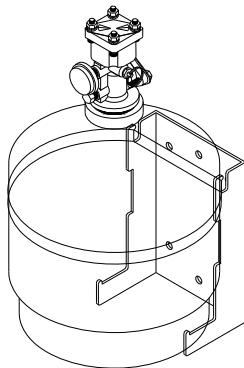

Figure 2-18.
Model MB-1,
Shown With BFR-5 Cylinder

The **Model MB-2** Mounting Bracket is used to mount the **Model BFR-10**, **Model BFR-15**, or **Model BFR-20** cylinders. See **Figure 2-19**.

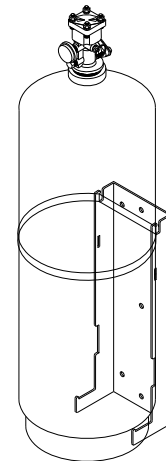

Figure 2-19.
Model MB-2,
Shown With BFR-20 Cylinder

Remote Mechanical Pull Stations

The **Model RPS-M** Remote Mechanical Pull Station and **Model RPS-M-RM** Remote Mechanical Pull Station Recessed Mount, provides remote mechanical actuation of the Systems Releasing Module(s). It is connected to the Systems Releasing Module(s) with:

- 1/16" (0.16 cm) stainless steel cable enclosed in 1/2" (1.3 cm) EMT conduit with a corner pulley at each change of direction.
- Buckeye Shielded Cable which does not require a corner pulley at each change of direction or conduit.
- A combination of both.

A remote pull station is required at the point of egress from the hazard area being protected. See **Figure 2-20** and **Figure 2-21**.

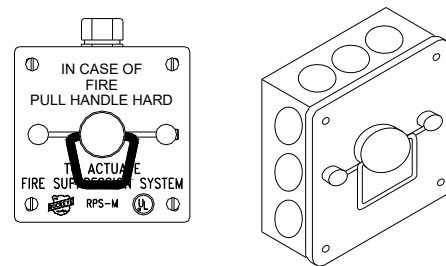

Figure 2-20.
Model RPS-M,
Remote Mechanical Pull Station

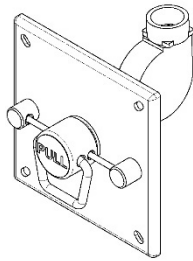

Figure 2-21.
Model RPS-M-RM,
Remote Mechanical Pull Station- Recessed Mount

Mechanical Gas Shutoff Valves

A gas shutoff valve is required for all systems protecting gas fueled appliances. A mechanical means of stopping gas flow is provided by the **Models BFGV-75 / 100 / 125 / 150 / 200 / 250 / 300** Gas Shutoff Valves. It is connected to the Systems Releasing Module(s) with:

- 1/16" (0.16 cm) stainless steel cable enclosed in 1/2" (1.3 cm) EMT conduit with a corner pulley at each change of direction.
- Buckeye Shielded Cable which does not require a corner pulley at each change of direction or conduit.
- A combination of both.

The valves are rated for natural or LP gas (see **Figure 2-22**) and are available in the following sizes:

Model Number	Valve Size In (cm)	Maximum Operating Pressure
BFGV-75	¾ (1.9)	5 psi (.4 bar)
BFGV-100	1 (2.5)	5 psi (.4 bar)
BFGV-125	1 ¼ (3.2)	5 psi (.4 bar)
BFGV-150	1 ½ (3.8)	5 psi (.4 bar)
BFGV-200	2 (5.1)	5 psi (.4 bar)
BFGV-250	2 ½ (6.4)	5 psi (.4 bar)
BFGV-300	3 (7.6)	5 psi (.4 bar)

Note: Gas valve size must be no smaller than the size of the gas line it is connected to.

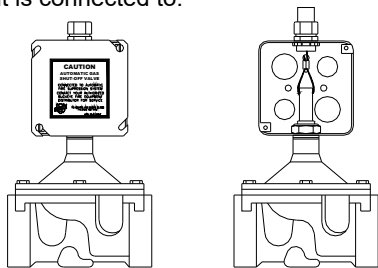

Figure 2-22.
Model BFGV-XXX,
Mechanical Gas Valve

Fusible Link Bracket Kit

The **Model FLB-1** Fusible Link Bracket kit (see **Figure 2-23**) includes the following:

- Standard high profile 10" (25 cm) fusible link bracket.
- Two (2) ½" (1.3 cm) EMT connectors.
- Two (2) cable crimps.
- Two (2) "S" hooks.

Note: Fusible links must be ordered separately.

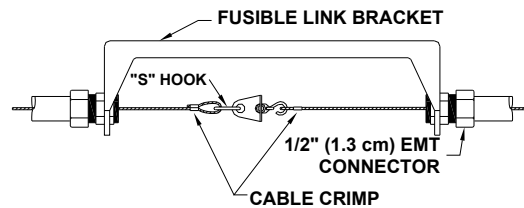

Figure 2-23.
Model FLB-1,
10" (25 cm) Fusible Link Bracket Assembly

Fusible Link Holder

The **Model FLH** Fusible Link Holder is designed to allow for the use of a continuous fusible link line, thus eliminating the need to cut and crimp each individual fusible link. They can be used either with or without fusible link brackets. They are available in packages of 25 (**Model FLH-25**). See **Figure 2-24**.

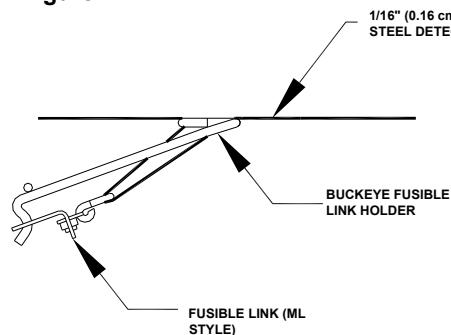

Figure 2-24.
Model FLH,
Fusible Link Holder

Buckeye Shielded Cable

As an alternative to using conduit and corner pulleys to connect the fusible link system, gas valve, and/or remote pull station to the Systems Releasing Module(s), the *Kitchen Mister* System utilizes Buckeye Shielded Cable to perform this function. Buckeye Shielded Cable is 1/16" (0.16 cm) stainless steel cable encased in a protective, flexible conduit. See **Figure 2-25**.



Buckeye Shielded Cable requires no conduit or corner pulleys, as the name implies, provided it is installed in accordance with the guidelines set forth in this manual.

Model BFR-SC-100 comes with 105 feet (32 m) of flexible conduit with 210 feet (64 m) of 1/16" (0.16 cm) stainless steel cable inside it.

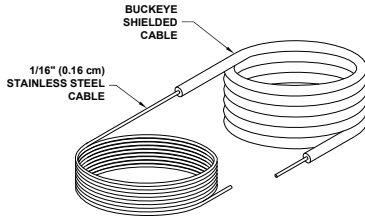

Figure 2-25.
Model BFR-SC-100,
Buckeye Shielded Cable

Shielded Cable Interface

The **Model BFR-SCI** Buckeye Shielded Cable Interface is required for connecting Buckeye Shielded Cable to any standard 1/2" (1.3 cm) EMT conduit connector or corner pulley. See **Figure 2-26**.

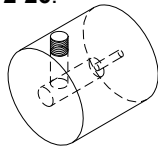

Figure 2-26.
Model BFR-SCI,
Shielded Cable Interface

Note: A 3/32" (0.2 cm) hex wrench is required to tighten the set screw.

Compression Type Corner Pulley

When Buckeye Shielded Cable **IS NOT** used to connect the fusible link system, gas valve, and/or remote pull station to the control head, a corner pulley is required whenever a change in stainless steel cable direction is necessary. The **Model CPCT-1** corner pulley is equipped with a compression type fitting that connects to standard 1/2" (1.3 cm) EMT conduit. See **Figure 2-27**.

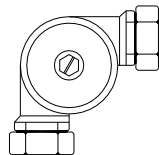

Figure 2-27.
Model CPCT-1,
Compression Type Corner Pulley

Discharge Nozzles

Misting type discharge nozzles have been specifically developed for appliance, duct, and plenum applications.

Each nozzle has a predetermined flow point value and comes equipped with a blow-off cap to protect the end orifice from blockage. Each nozzle is identified by the model number stamped on the nozzle body and has a unique color band for easy visual identification. See **Figure 2-28**.

Model Number	Flow Points	Band Color
N-1HP	1	Blue
N-1LP	1	Red
N-2HP	2	Green
N-2LP	2	Yellow
N-2W	2	White

Note: Details on specific nozzle applications can be found in the Design Section of this manual.

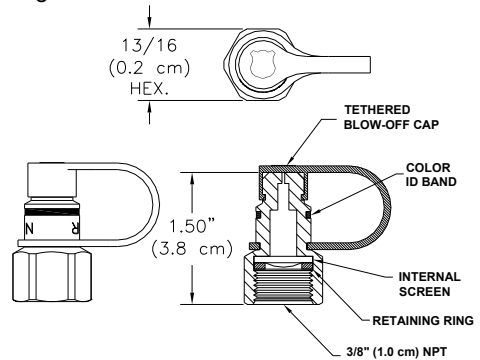

Figure 2-28.
Discharge Nozzle

Swivel Nozzle Adaptor

The **Model N-SA** Swivel Adaptor can be used with any discharge nozzle to facilitate the nozzle aiming process. They are chrome plated and allow for a 30° rotation of the nozzle in any direction. See **Figure 2-29**.

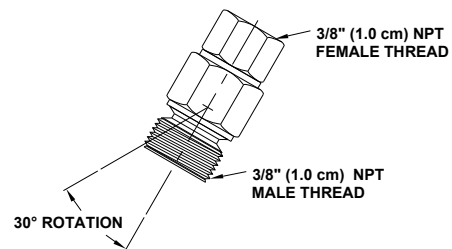

Figure 2-29.
Model N-SA,
Swivel Adaptor

Pipe and Fittings

Pipe and fittings must be furnished by the installer. Pipe shall be Schedule 40 black, chrome plated, or stainless-steel pipe. Fittings shall be rated 150 LB (68 kg).



COMPONENT LIST

Model Number	Description	Part Number
BFGV-075	3/4" (1.9 cm) Mechanical Gas Valve	HV216-585-1
BFGV-100	1" (2.5 cm) Mechanical Gas Valve	HV216-585-2
BFGV-125	1-1/4" (3.2 cm) Mechanical Gas Valve	HV216-585-3
BFGV-150	1-1/2" (3.8 cm) Mechanical Gas Valve	HV216-585-4
BFGV-200	2" (5 cm) Mechanical Gas Valve	HV216-585-5
BFGV-250	2-1/2" (6.4 cm) Mechanical Gas Valve	HV216-585-6
BFGV-300	3" (7.6 cm) Mechanical Gas Valve	HV216-585-7
BFR-10	10 Flow Point Cylinder w/ Valve	BFR10
BFR-10R	Recharge Agent (10 Flow Point)	BFR10R
BFR-15	15 Flow Point Cylinder w/ Valve	BFR15
BFR-20	20 Flow Point Cylinder w/ Valve	BFR20
BFR-5	5 Flow Point Cylinder w/ Valve	BFR5
BFR-5R	Recharge Agent (5 Flow Point)	BFR5R
BFR-5T	Restaurant Test Cylinder	BFR5T
BFR-AC-L	Large Nitrogen Actuation Cartridge (2 per package)	BFRACL
BFR-AC-L1	Large Nitrogen Actuation Cartridge	PCH10134
BFR-AC-S	Small Nitrogen Actuation Cartridge (5 per package)	BFRACS
BFR-AC-S1	Small Nitrogen Actuation Cartridge	PCH10133
BFR-CAP	Valve Cap Assembly	BFRCAP
BFR-DAK	Replacement Discharge Adaptor Kit	BFRDAK
BFR-FHD	Flexible Hex Driver	BFRFHD
BFR-OM	Owner's Manual	BFROM

Model Number	Description	Part Number
BFR-PG	195 psi (1334 KPa) Pressure Gauge	BFRPG
BFR-SC	Buckeye Shielded Cable	PMI10175
BFR-SC-100	Shielded Stainless Steel Cable [105 feet (32 m)]	BFRSC100
BFR-SCI	Shielded Cable Interface	PMI10186
BFR-SCI-10	Shielded Stainless Steel Cable Interface (10 per package)	BFRSCI10
BFR-SSFH	Stainless Steel Flexible Discharge Hose	BFRSSFH
BFR-TM	System Technical Manual	BFRTM
BFR-TP-1	Tee Pulley	BFRTP1
BFR-TVA	Test Valve Assembly	BFRTVA
BFR-UBC-10	Stainless Steel Upright Broiler Nozzle Cap Kit (10 per package)	BFRUBC10
BFR-UBCT-5	Metal Tethered Nozzle Cap Kit (5 per package)	BFRUBCT5
BFR-VIG	SRM / Valve Interface Gasket	POS10123
BFR-VIG-10	SRM / Valve Interface Gasket (10 per package)	BFRVIG10
BFR-VLV	Complete Valve Assembly	BFRVLV
BFR-VRK	Valve Rebuilding Kit	BFRVRK
BFR-VRT	Valve Rebuilding Tool	BFRVRT
BFR-VRT	Valve Rebuilding Tool	BFRVRT
CPCT-1	Compression Seal Type Corner Pulley	CP5
CPCT-25	Compression Seal Type Corner Pulley (25 per package)	CP5
CQS-38P	Hood Quickseal - Compression Type for 3/8" (17.1 mm OD) PIPE	CQS38P
CQS-50C	Hood Quickseal - Compression Type for 1/2" (1.3 cm) EMT	CQS50C



Model Number	Description	Part Number
CQS-50P	Hood Quickseal - Compression Type for 1/2" (21.3 mm OD) PIPE	CQS50P
FL-280	Fusible Link - 280° F (138° C).	Globe - ML
FL-280-10	Fusible Links - 280° F (138° C). (10 per package)	FL28010
FL-360	Fusible Links - 360° F (182° C).	Globe - ML
FL-360-10	Fusible Links - 360° F (182° C). (10 per package)	FL36010
FL-450	Fusible Links - 450° F (232° C).	Globe - ML
FL-450-10	Fusible Links - 450° F (232° C). (10 per package)	FL45010
FL-500	Fusible Links - 500° F (260° C).	Globe - ML
FL-500-10	Fusible Links - 500° F (260° C). (10 per package)	FL50010
FLB-1	10" (25.4 cm) Fusible Link Bracket Kit	FLB
FLB-10	10" (25.4 cm) Fusible Link Bracket Kit (10 per package)	FLB
FLH	Fusible Link Holder	PDE10038
FLH-25	Fusible Link Holder (25 per package)	FLH25
MB-1	Mounting Bracket for BFR-5	MB1
MB-2	Mounting Bracket for BFR-10/15/20	MB2
MS-AIS	Micro Switch - Alarm Initialing Switch	MSAIS
MS-DPDT	Micro Switch - DPDT	MSDPDT
N-1HP	1 Flow Point - High Proximity Nozzle	PNZN1HP
N-1HP-10	1 Flow Point - High Proximity Nozzle (10 per package)	N1HP10
N-1LP	1 Flow Point - Low Proximity Nozzle	PNZN1LP
N-1LP-10	1 Flow Point - Low Proximity Nozzle (10 per package)	N1LP10
N-2HP	2 Flow Point - High Proximity Nozzle	PNZN2HP

Model Number	Description	Part Number
N-2HP-10	2 Flow Point - High Proximity Nozzle (10 per package)	N2HP10
N-2LP	2 Flow Point - Low Proximity Nozzle	PNZN2LP
N-2LP-10	2 Flow Point - Low Proximity Nozzle (10 per package)	N2LP10
N-2W	2 Flow Point - Wide Angle Nozzle	PNZN2W
N-2W-10	2 Flow Point - Wide Angle Nozzle (10 per package)	N2W10
N-CAP	Replacement Nozzle Cap	PNZ10207
N-CAP-10	Replacement Nozzle Caps (10 per package)	NCAP10
N-SA	Swivel Adaptor - Fits all nozzles.	NSA
N-STR	Replacement Nozzle Strainers	PNZ10209
N-STR-10	Replacement Nozzle Strainers (10 per package)	NSTR10
QS-38P	Hood Quickseal - Threaded for 3/8" (17.1 mm OD) PIPE	QS38P
QS-50P	Hood Quickseal - Threaded for 1/2" (21.3 mm OD) PIPE	QS50P
RPS-BR-10	Replacement Break Rods (10 per package)	RPSBR10
RPS-M	Remote Mechanical Pull Station	RPSM
RPSM-RM	Remote Mechanical Pull Station – Recessed Mount	RPSM
SH	"S" Hooks	PHF10169
SH-100	"S" Hooks (100 per package)	SH100
SM-120	Solenoid Monitor, 120VAC	SM120
SM-24	Solenoid Monitor, 24VDC	SM24
SRM	Systems Releasing Module(s) w/ Single Fusible Link Line	SRM
SRM2-E-120	Systems Releasing Module - Electric, 120 VAC	SRM2E120
SRM2-E-24	Systems Releasing Module - Electric, 24 VDC	SRM2E24



Model Number	Description	Part Number
SRM2-M	Systems Releasing Module - Mechanical w/ Single Fusible Link Line	SRM2M
SRM-D	Systems Releasing Module w/ Two Fusible Link Lines	SRMD
TD-225	Thermal Detector - 225o F (107o C).	TD225
TD-325	Thermal Detector - 325o F (163o C).	TD325
TD-450	Thermal Detector - 450o F (232o C).	TD450
TD-600	Thermal Detector - 600o F (316o C).	TD600
WC-116	Wire Crimps for 1/16" (0.16 cm) Cable	PHF10076
WC-116-100	Wire Crimps for 1/16" (0.16 cm) Cable (100 per package)	WC116100
WR-116	Cable, Stainless Steel, 1/16" (0.16 cm) 7X7 Stranded	PMI10176
WR-116-100	Stainless Steel Wire Rope - 1/16" (0.16 cm) Diameter [100 feet (30.5 m)]	WR116100
WR-116-500	Stainless Steel Wire Rope - 1/16" (0.16 cm) Diameter [500 feet (152 m)]	WR116500



Chapter 3 System Design

OVERVIEW OF SYSTEM DESIGN

The following chapter will cover the proper design of the Buckeye Fire Equipment *Kitchen Mister* Fire Suppression System. It is divided into three sections:

1. Nozzle Coverages and Placements
2. Piping Limitations
3. Detector Placement

Design of the *Kitchen Mister* System must be in compliance with the parameters set forth in this manual and be performed by a factory trained, Authorized Buckeye Fire Equipment Dealer. Buckeye Fire Equipment is not responsible for systems installed or maintained by personnel that are not factory trained and Authorized.

NOZZLE COVERAGE, PLACEMENT, AND AIMING

This section will give detailed guidelines for determining nozzle type, positioning, and aim point for appliance, plenum, and duct protection.

Duct Protection

It is not necessary to shut down or damper the exhaust fan for the system to function properly. It is recommended that the exhaust fan be left on during system discharge to help distribute the extinguishing agent throughout the ductwork.

Ducts - 50" (127 cm) Maximum Perimeter

Nozzle: N-1LP (1 Flow Point)

Coverage: Unlimited length with:
50" (127 cm) Maximum Perimeter with a longest side of 16-3/4" (43 cm) for rectangular ducts and 12-1/2" (32 cm) for square ducts
or
50" (127 cm) Maximum Circumference (maximum diameter of 16" (41 cm)) for round ducts.

Placement: Centered in duct opening, from 1-6" (2.5-15 cm) into the duct opening.

Aim point: Center of duct.

The **Model N-1LP** nozzle is a one flow point nozzle that can protect a square or rectangular duct of unlimited

length and changes of direction with a maximum 50" (127 cm) perimeter and a maximum one side length of 12-1/2" (32 cm) (square) and 16-3/4" (43 cm) (rectangular) respectively. It can also protect a round duct with a maximum circumference of 50" (127 cm) [16" (41 cm) maximum diameter]. See **Figure 3-1 & 3-2**.

Ducts - 150" (381 cm) Maximum Perimeter

Nozzle: N-2W (2 Flow Point)

Coverage: Unlimited length with:
150" (381 cm) Maximum Perimeter with a longest side of 50" (127 cm) for rectangular ducts and 37-1/2" (95 cm) for square ducts
or
150" (381 cm) Maximum Circumference [maximum diameter of 47-1/2" (121 cm)] for round ducts.

Placement: Centered in duct opening, from 0-6" (0-15 cm) into the duct opening.

Aim point: Center of duct.

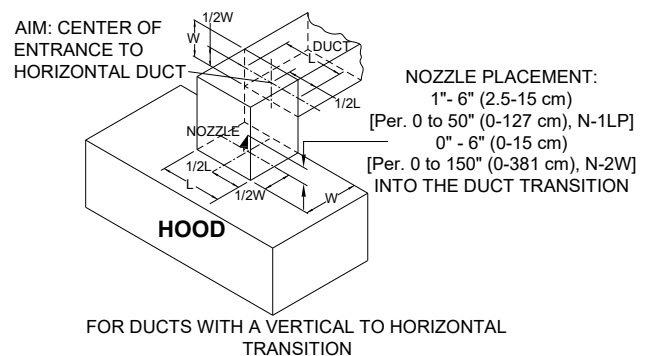
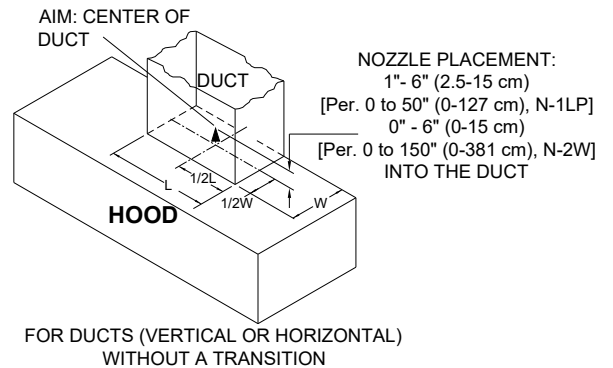
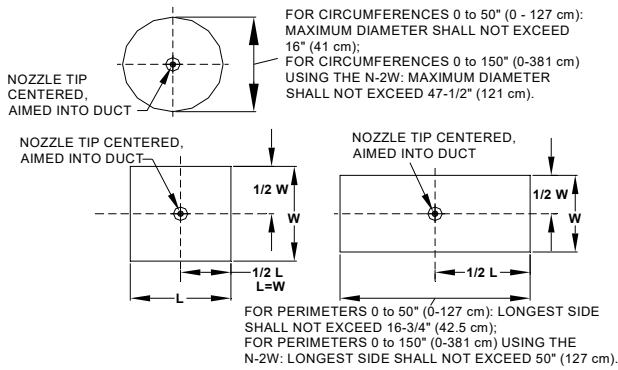

Figure 3-1.
Proper Duct Nozzle Placement



VIEW OF DUCT CROSS-SECTIONAL AREA

Figure 3-2.
Proper Duct Nozzle Placement

The **Model N-2W** nozzle is a two (2) flow point nozzle that can protect a square or rectangular duct of unlimited length and changes of direction with a maximum 150" (381 cm) perimeter and a maximum one side length of 37-1/2" (95 cm) (square) and 50" (127 cm) (rectangular) respectively. It can also protect a round duct with a maximum circumference of 150" (381 cm) (47-1/2" (121 cm) maximum diameter). See **Figure 3-1 and 3-2**.

Ducts Larger than 150" (381 cm) Perimeter

For ducts with perimeters larger than 150" (381 cm), more than one **Model N-2W** nozzle must be used. When using multiple **Model N-2W** nozzles to protect a single duct, the cross-sectional area of the duct must be divided into equal symmetrical areas. Each nozzle must then be installed in the center of the area it is protecting and aimed directly into the duct opening. No cross-sectional area can exceed the single nozzle coverage.

Transition Ducts

Protection of any non-standard duct should be discussed and agreed upon with the local authority having jurisdiction before proceeding with any system installation. Typically, transition ducts are protected in the following manner.

Larger to Smaller Duct Transitions

To determine the proper coverage for ducts that have a larger opening into the plenum than the final exhaust duct, measure the perimeter of the duct half way between the largest and smallest cross-sectional areas. The nozzle will be located as per standard duct coverage at the duct/plenum interface, rather than at the point of measurement, and pointed into the duct, aimed at the center of the final duct opening. See **Figure 3.3**.

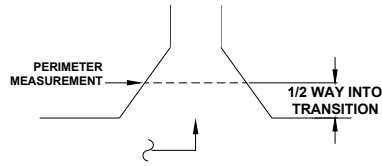

Figure 3.3.
Proper Measurement and Nozzle Placement for Larger To Smaller Transition Ducts.

Smaller to Larger Duct Transitions

To determine the proper coverage for ducts that have a smaller opening into the plenum than the final exhaust duct, measure the perimeter of the final exhaust duct. The nozzle will be located as per standard duct coverage at the duct/plenum interface and aimed at the center of the duct opening. See **Figure 3.4**.

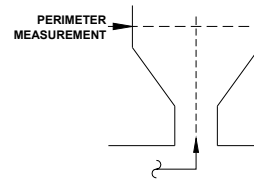

Figure 3.4.
Proper Measurement and Nozzle Placement for Smaller To Larger Transition Ducts.

Upper / Lower Plenums

When protecting exhaust hoods with multiple risers (upper / lower plenums), each riser must be protected as an individual duct. See **Figure 3.5**.

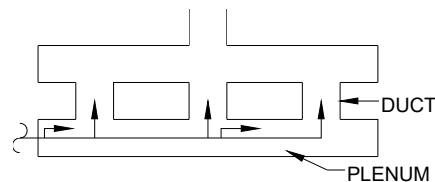

Figure 3.5.
Upper / Lower Plenum Protection

Electrostatic Precipitators

Ventilation systems that utilize electrostatic precipitators require duct protection above and below the precipitator. Standard duct nozzles are used for this application. See **Figure 3.6**.

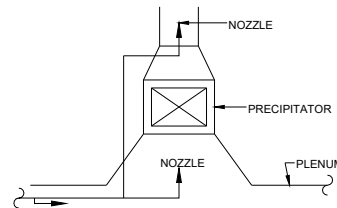

Figure 3.6.
Electrostatic Precipitator Protection.



Plenum Protection

Nozzle: N-1HP (1 Flow Point)

Coverage: Length: 12 feet (3.7 m) max.
Width: 4 feet (1.2 m) max.

Placement: See **Figure 3-7**.

Aim point: See **Figure 3-7**.

The **Model N-1HP** nozzle is a one (1) flow point nozzle that can protect a plenum (either single bank or V-bank) of 12 feet (3.7 m) in length and 4 feet (1.2 m) in width per nozzle. Larger plenums must be divided into 12-foot (3.7 m) sections, with each section protected with a separate nozzle. See **Figure 3-7**.

Plenum: V-bank Nozzle Placement

The nozzle must be located at the center of the V-bank width and down 1/3 of the vertical height, within 6 inches (15 cm) of the end of the plenum or plenum module and aimed down the length of the plenum. See **Figure 3-7**.

Plenum: Single Filter Bank Nozzle Placement

The nozzle must be located at a point that is 2" (5.1 cm) from the back edge of the **filter** and 1/3 of the vertical height of the **filter**, within 6 inches (15 cm) off the end of the plenum or plenum module and aimed down the length of the plenum. See **Figure 3-7**.

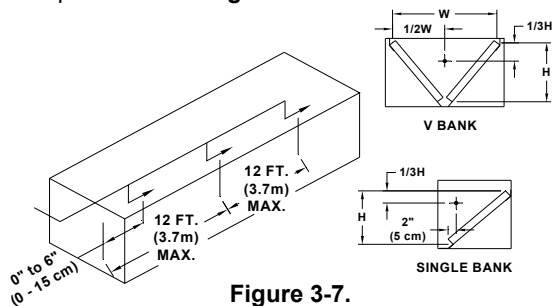

Figure 3-7.
Model N-1HP
Plenum Nozzle Placement and Aiming

Note: These examples are typical and do not represent every acceptable nozzle configuration, only a representative sample of them.

Designer Note

For plenums that exceed 12 feet (3.7 m) in length and therefore require multiple nozzles, it is recommended that the total length be divided into equally sized protection zones and protected accordingly. So a 16 foot (4.9 m) long plenum should be divided into two 8 foot (2.4 m) zones, with a nozzle protecting each, as opposed to a 12 foot (3.7 m) zone and a 4 foot (1.2 m) zone.

APPLIANCE PROTECTION

Each different appliance must be protected in a specific manner with regard to nozzle selection, placement, and aiming. No deviations from these parameters are allowed and failure to comply completely with these requirements will void the UL Listing of the system and may render the system ineffective.

In order to properly understand this section, several key terms need to be defined in advance.

DESIGN TERMINOLOGY

Nozzle Height: The distance from the tip of the discharge nozzle to the top surface of the appliance (except for woks, in which case the bottom of the wok is used).

Hazard Area: All nozzle coverages include the maximum size of the hazard area they can protect. **Hazard area is NOT the overall size of the appliance being protected**, but rather the actual size of the portion of the appliance used for cooking.

Appliances Requiring Multiple Nozzles

Some appliances may need to be protected by multiple nozzles because of their size. If the size of an appliance is larger than the approved coverage for that appliance, multiple nozzles must be used. This is accomplished by dividing the hazard area into individual zones that comply with the parameters of the listing for that appliance. In this case, each zone will be protected as an individual appliance with respect to nozzle placement and aiming.

RANGE PROTECTION

Two (2) Burner Range – LOW Proximity

Nozzle: N-1LP (1 Flow Point)

Coverage: 12" (30.5 cm) x 24" (61 cm) Maximum (measured burner edge to burner edge)

Nozzle Ht: 16" (41 cm) – 30" (76 cm)

Placement: 3" (7.6 cm) from either edge of appliance, on appliance's long centerline.

Aim point: 6" (15 cm) from opposite edge of appliance, on appliance's long centerline.

The **Model N-1LP** nozzle is a one (1) flow point nozzle that can protect a range cooking area of 12" (30.5 cm) wide by 24" (61 cm) deep. The nozzle must be located 16" (41 cm) to 30" (76 cm) above the cooking surface and positioned on the appliance's long centerline within 3" (7.6 cm) of either the front or back edge of the appliance. The nozzle must be aimed at the appliance's long



centerline 6" (15 cm) off the opposite edge of the appliance. See **Figure 3-8**.

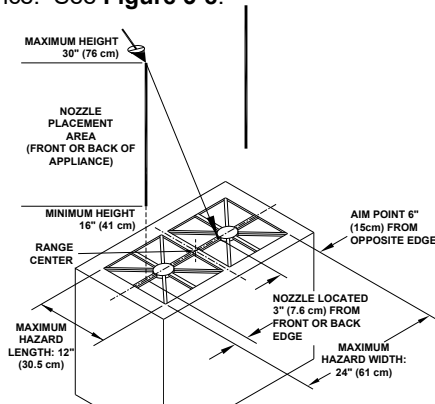

Figure 3-8.

**Low Proximity, 12" (30.5 cm) x 24" (61 cm) Range
Model N-1LP Nozzle**

Four (4) Burner Ranges:

1) Four Burner Range – HIGH Proximity

Nozzle: N-1LP (1 Flow Point)

Coverage: 24" (61 cm) x 24" (61 cm) Maximum (measured burner edge to burner edge)

Nozzle Ht: 30" (76 cm) – 40" (102 cm)

Placement: Within 3" (7.6 cm) of the center of appliance.

Aim point: Center of appliance.

The **Model N-1LP** nozzle is a one (1) flow point nozzle that can protect a range cooking area of 24" (61 cm) wide by 24" (61 cm) deep. The nozzle must be located 30" (76 cm) to 40" (102 cm) above the cooking surface and within 3" (7.6 cm) of the center of the appliance. The nozzle must be aimed at the center of the cooking area. See **Figure 3-9**.

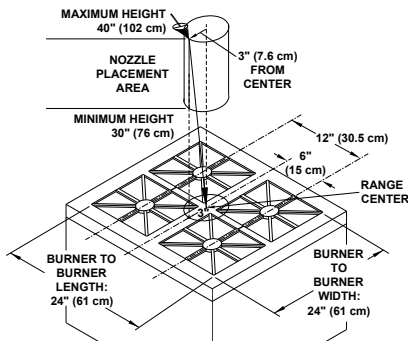

Figure 3-9.

**High Proximity, 24" (61 cm) x 24" (61 cm) Range
Model N-1LP Nozzle**

2) Four Burner Range – LOW Proximity

Nozzle: N-2W (2 Flow Point)

Coverage: 24" (61 cm) x 24" (61 cm) Maximum (measured burner edge to burner edge)

Nozzle Ht: 16" (41 cm) – 30" (76 cm)

Placement: Center of appliance.

Aim point: Center of appliance.

The **Model N-2W** nozzle is a two (2) flow point nozzle that can protect a range cooking area of 24" (61 cm) wide by 24" (61 cm) deep. The nozzle must be located 16" (41 cm) to 30" (76 cm) above the cooking surface and be centered over the appliance. The nozzle must be aimed at the center of the cooking area. See **Figure 3-10**.

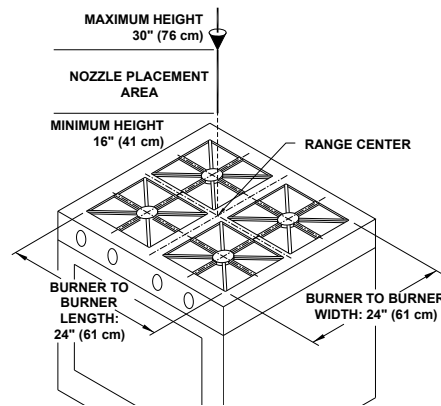

Figure 3-10.

**Low Proximity, 24" (61 cm) x 24" (61 cm) Range
Model N-2W Nozzle**

Six (6) Burner Range

Nozzle: N-2LP (2 Flow Point)

Coverage: 36" (91 cm) x 24" (61 cm) Maximum (measured burner edge to burner edge)

Nozzle Ht: 35" (89 cm) – 43" (109 cm)

Placement: Centered over appliance.

Aim point: Center of appliance.

The **Model N-2LP** nozzle is a two (2) flow point nozzle that can protect a range cooking area of 36" (91 cm) wide by 24" (61 cm) deep. The nozzle must be located 35" (89 cm) to 43" (109 cm) above the cooking surface and centered over the appliance. The nozzle must be aimed at the center of the cooking area. See **Figure 3-11**.

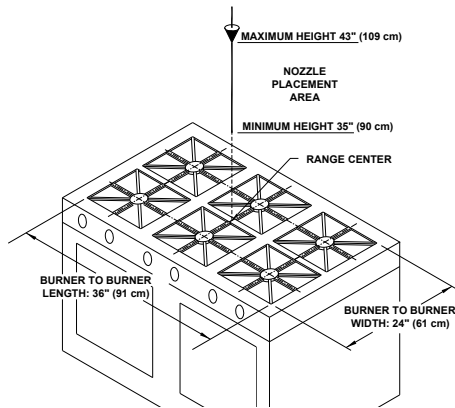

Figure 3-11.
36" (91 cm) x 24" (61 cm) Range
Model N-2LP Nozzle

Range / Griddle Combination Appliance

Nozzle: N-1LP (1 Flow Point)

Coverage: 30" (76 cm) x 24" (61 cm) Maximum
 (measured burner edge to burner edge)

Nozzle Ht: 30" (76 cm) – 40" (102 cm)

Placement: Within 3" (7.6 cm) of the center of
 appliance.

Aim point: Center of appliance.

The **Model N-1LP** nozzle is a one (1) flow point nozzle that can protect a combination range / griddle with a cooking area of 30" (76 cm) wide by 24" (61 cm) deep. The nozzle must be located 30" (76 cm) to 40" (102 cm) above the cooking surface and within 3" (7.6 cm) of the center of the appliance. The nozzle must be aimed at the center of the cooking area. See **Figure 3-11**.

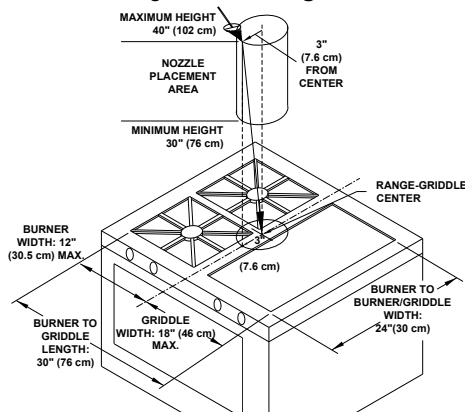

Figure 3-12.
30" (76 cm) x 24" (61 cm) Combination
Range / Griddle
Model N-1LP Nozzle

Protection For Appliances With a Back-shelf

The protection of an appliance (such as a range) that has a shelf that can interfere with a nozzle discharge can be accomplished by either using the low proximity coverage for that appliance or placing the nozzle in a position within its stated limitation where the discharge pattern will not be affected. Sample coverages for a range with a back-shelf are shown in **Figures 3-13** and **3-14**.

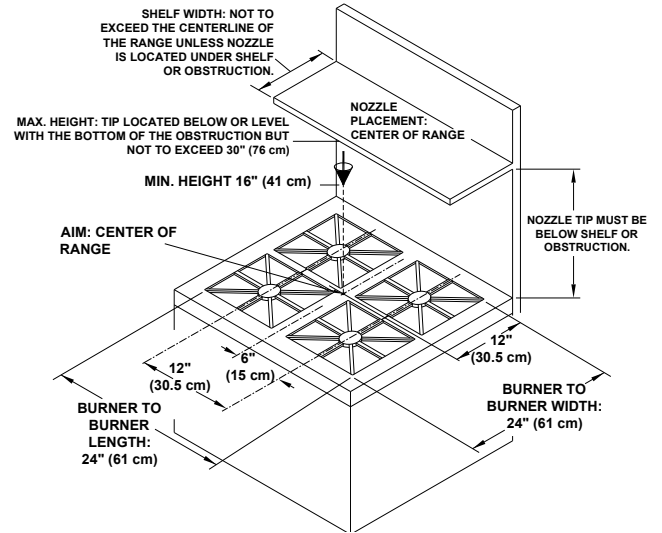

Figure 3-13.
24" (61 cm) x 24" (61 cm) Range with Back-shelf
Model N-2W Nozzle

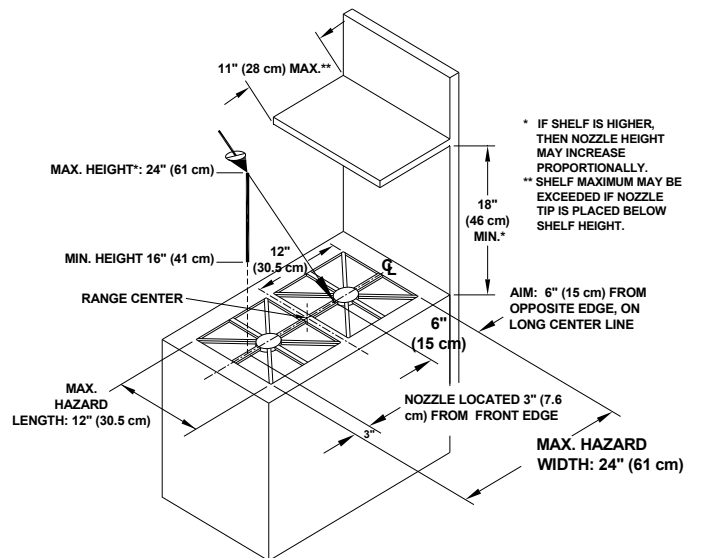

Figure 3-14.
12" (30.5 cm) x 24" (61 cm) Range with Back-shelf
Model N-1LP Nozzle



Four Burner Range with a Back-shelf
– HIGH Proximity

- Nozzle:** N-2LP (2 Flow Point)
- Coverage:** 24" (61 cm) x 24" (61 cm) Maximum (measured burner edge to burner edge)
- Nozzle Ht:** 30" (76 cm) – 40" (102 cm)
- Placement:** 6" (15 cm) outside the front edge of the burners within 9" (22.6 cm) from the centerline.
- Aim point:** 6" (15 cm) from the back edge of the burner on the centerline of the appliance.
- Shelf Height:** Minimum of 16" (41 cm) from the top of the appliance.
- Shelf Width:** A maximum of 11" (28 cm).

The **Model N-2LP** nozzle is a two (2) flow point nozzle that can protect a range cooking area of 24" (61 cm) wide by 24" (61 cm) deep. The nozzle must be located 30" (76 cm) to 40" (102 cm) above the cooking surface 6" (15 cm) from the front edge of the burners and within 9" (22.5 cm) of the centerline of the appliance. The nozzle must be aimed 6" (15 cm) from the back edge of the burner on the centerline of the appliance. The back shelf shall not be less than 16" (41 cm) from the top of the appliance and extend more than 11" (28 cm) over the back edge of the burners. See **Figure 3-14a**.

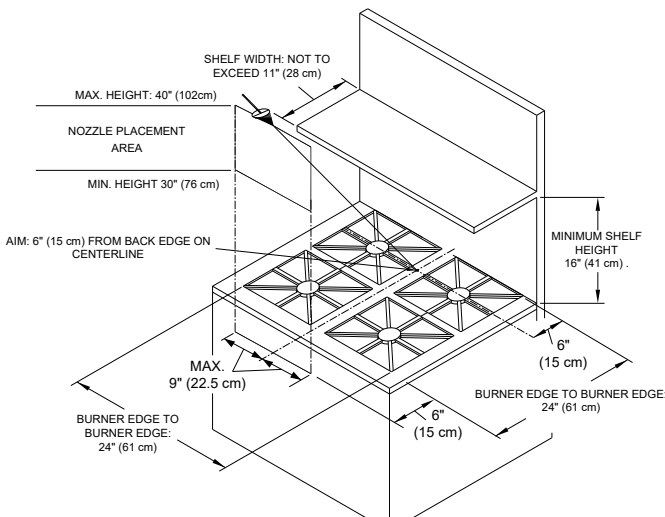

Figure 3-14a.
24" (61 cm) x 24" (61cm) Range with Back-shelf
Model N-2LP Nozzle

Wok Protection

- Nozzle:** N-1HP (1 Flow Point)
- Coverage:** 12" (30.5 cm) Min. x 30" (76 cm) Max.
- Nozzle Ht:** 30" (76 cm) – 48" (122 cm) (measured from bottom)
- Placement:** Anywhere over the surface of the appliance.
- Aim Point:** Center of bottom of appliance.

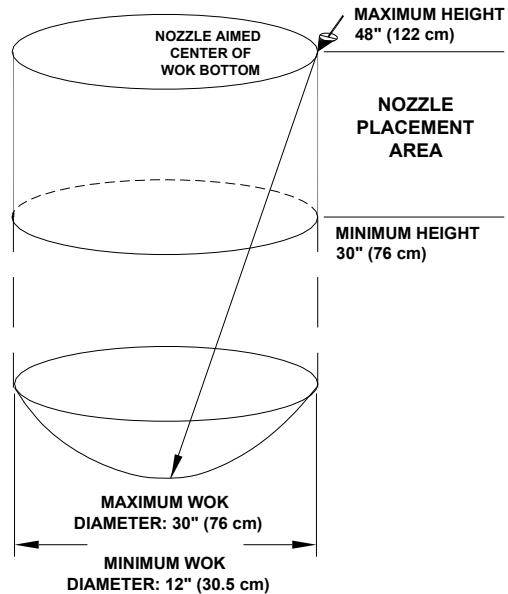

Figure 3-14b.
Wok Protection
Model N-1HP Nozzle

The **Model N-1HP** nozzle is a one (1) flow point nozzle that can protect a wok with a minimum diameter of 12" (30.5 cm) up to a maximum diameter of 30" (76 cm). The nozzle must be located 30" (76 cm) to 48" (122 cm) above the bottom of the wok and positioned anywhere over the cooking area. The nozzle must be aimed at the center of the cooking area. See **Figure 3-14b**.



Deep Fat Fryer Protection

- Nozzle:** N-2HP (2 Flow Point)
- Coverage:** 20.25" (51 cm) x 24" (61 cm)
- Nozzle Ht:** 24" (61 cm) – 45" (114 cm)
- Placement:** Anywhere over the surface of the appliance cooking area.
- Aim point:** Center of appliance.

The **Model N-2HP** nozzle is a two (2) flow point nozzle that can protect a deep fat fryer with a maximum cooking area of 20.25" (51 cm) wide by 24" (61 cm) deep. The nozzle must be located 24" (61 cm) to 45" (114 cm) above the cooking surface and located anywhere over the appliance cooking area. The nozzle must be aimed at the center of the cooking area. See **Figure 3-15**.

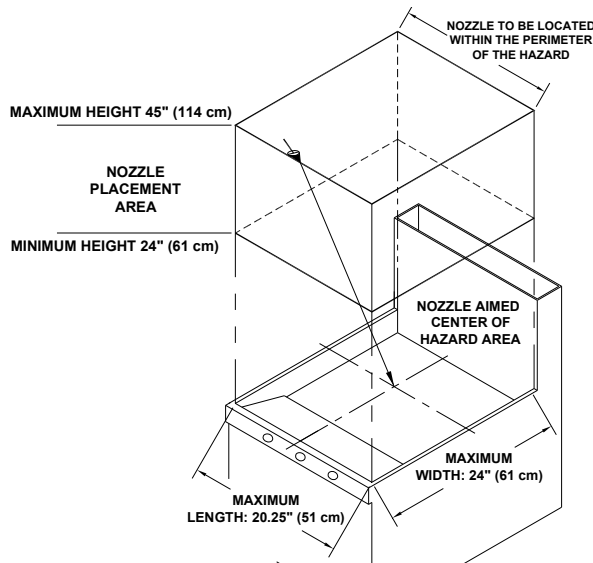

Figure 3-15.
20.25" (cm) x 24" (cm) Deep Fat Fryer
Model N-2HP Nozzle

Fryers Requiring Multiple Nozzles

Fryers that exceed the coverage of a single nozzle can be protected with multiple nozzles. The fryer must be divided into equal sized modules, so that each module does not exceed the maximum coverage allowed for a single nozzle.

CAUTION

The maximum size fryer that can be modularized is 864 square inches (5,574 sq. cm).

Tilting Skillet/ Brazing Pan Protection

- Nozzle:** N-2HP (2 Flow Point)
- Coverage:** 20.25" (51 cm) x 24" (61 cm) per nozzle
- Nozzle Ht:** 24" (61 cm) – 45" (114 cm)
- Placement:** Anywhere over the surface of the appliance cooking area.
- Aim Point:** Center of the protected zone.

The **Model N-2HP** nozzle is a two (2) flow point nozzle that can protect a tilting skillet / brazing pan with a maximum cooking area of 20.25" (51 cm) wide by 24" (61 cm) deep per nozzle. The nozzle must be located 24" (61 cm) to 45" (114 cm) above the cooking surface and located anywhere over the appliance cooking area. The nozzle must be aimed at the center of the cooking area. See **Figure 3-16**.

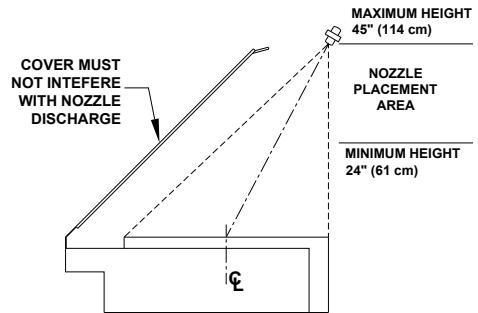

Figure 3-16.
Tilting Skillet / Brazing Pan
Model N-2HP Nozzle

GRIDDLE PROTECTION

Standard Griddle: 42" (107 cm) x 30" (76 cm)

- Nozzle:** N-1LP (1 Flow Point)
- Coverage:** 42" (107 cm) x 30" (76 cm) Maximum
- Nozzle Ht:** 24" (61 cm) – 48" (122 cm)
- Placement:** Directly over the edge of the cooking area.
- Aim Point:** 6" (15 cm) from center of appliance in-line with the nozzle.

The **Model N-1LP** nozzle is a one (1) flow point nozzle that can protect a griddle with a maximum cooking area of 42" (107 cm) wide by 30" (76 cm) deep. The nozzle must be located 24" (61 cm) to 48" (122 cm) above the cooking surface and positioned directly above the edge of the cooking area. The nozzle must be aimed 6" (15 cm) from the center of the cooking area in-line with the nozzle. See **Figure 3-17**.

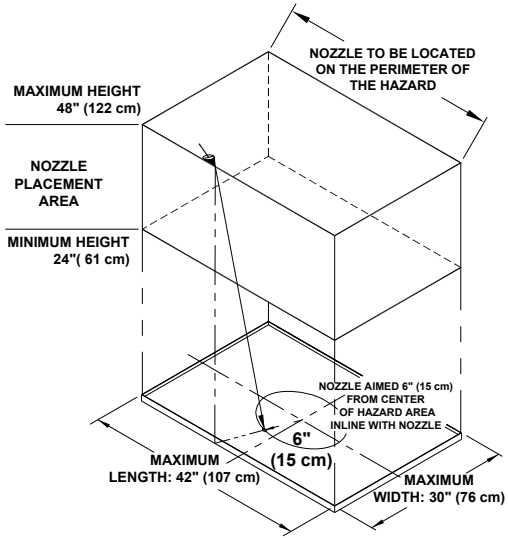

Figure 3-17.
Standard Griddle: 42" (107 cm) x 30" (76 cm)
Model N-1LP Nozzle

Large Griddle - 48" (122 cm) x 30" (76 cm)

- Nozzle:** N-1LP (1 Flow Point)
- Coverage:** 48" (122 cm) x 30" (76 cm) Maximum
- Nozzle Ht:** 30" (76 cm) – 43" (109 cm)
- Placement:** On the centerline of the appliance, 6" (15 cm) off the short edge.
- Aim Point:** 3" (7.6 cm) from center of appliance in-line with the nozzle.

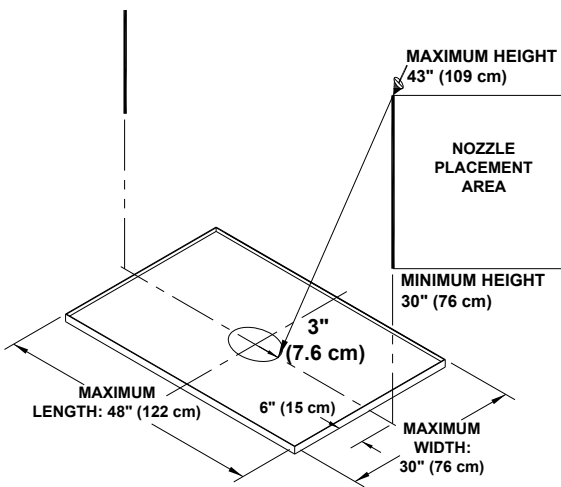

Figure 3-18.
Large Griddle: 48" (122 cm) x 30" (76 cm)
Model N-1LP Nozzle

The **Model N-1LP** nozzle is a one (1) flow point nozzle that can protect a griddle with a maximum cooking area of 48" (122 cm) wide by 30" (76 cm) deep. The nozzle must be located 30" (76 cm) to 43" (109 cm) above the cooking surface, on the centerline of the appliance and 6" (15 cm) off the either short edge. The nozzle must be aimed 3" (7.6 cm) from the center of the cooking area in-line with the nozzle. See **Figure 3-18**.

Extra Large Griddle - 60" (152 cm) x 30" (76 cm)

- Nozzle:** N-2LP (2 Flow Point)
- Coverage:** 60" (152 cm) x 30" (76 cm) Maximum
- Nozzle Ht:** 24" (61 cm) – 48" (122 cm)
- Placement:** Directly over the edge of the cooking area.
- Aim Point:** 8" (20 cm) from center of appliance in-line with the nozzle.

The **Model N-2LP** nozzle is a two (2) flow point nozzle that can protect a griddle with a maximum cooking area of 60" (152 cm) wide by 30" (76 cm) deep. The nozzle must be located 24" (61 cm) to 48" (122 cm) above the cooking surface and positioned directly above the edge of the cooking area. The nozzle must be aimed 8" (20 cm) from the center of the cooking area in-line with the nozzle. See **Figure 3-19**.

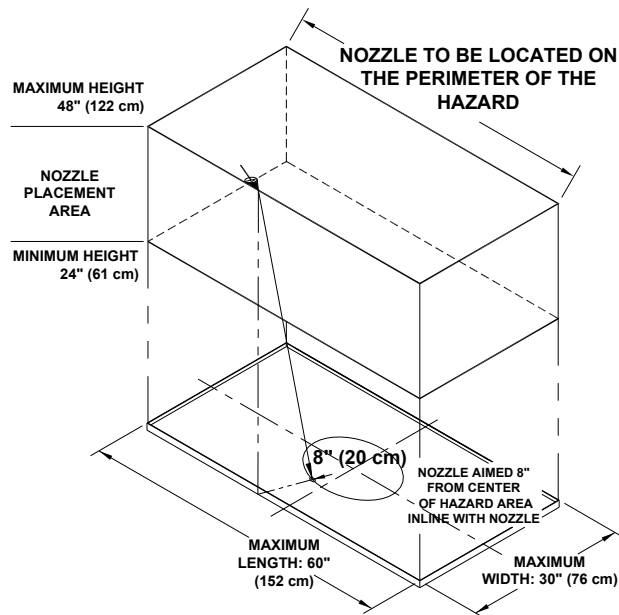

Figure 3-19.
Extra Large Griddle: 60" (152 cm) x 30" (76 cm)
Model N-2LP Nozzle



Extra Low Proximity Griddle

- Nozzle:** N-2W (2 Flow Point)
- Coverage:** 42" (107 cm) x 30" (76 cm) Maximum
- Nozzle Ht:** 2" (5 cm) – 10" (25 cm)
- Placement:** Over any corner, at a 45° angle to the surface.
- Aim Point:** At cooking surface, equal distance from both edges.

The **Model N-2W** nozzle is a two (2) flow point nozzle that can protect a griddle with a maximum cooking area of 42" (107 cm) wide by 30" (76 cm) deep. The nozzle must be located 2" (5 cm) to 10" (25 cm) above any corner of the cooking surface and positioned on the edge of the cooking area of the griddle. The nozzle must be aimed at the point over the cooking surface equal distance from both edges. See **Figure 3-19a**.

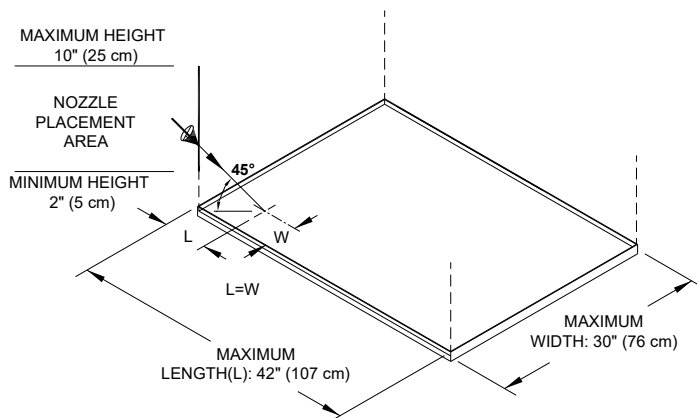

Figure 3-19a.
42" (107 cm) x 30" (76 cm) Griddle
Model N-2W Nozzle

Low Proximity Griddle

- Nozzle:** N-2W (2 Flow Point)
- Coverage:** 60" (152 cm) x 30" (76 cm) Maximum
- Nozzle Ht:** 10" (25 cm) – 30" (76 cm)
- Placement:** From 0" to 3" (7.6 cm) outside the short side edge of the cooking area,
- Aim Point:** One-quarter the length (1/4L) of the longest side, in-line with the nozzle.

The **Model N-2W** nozzle is a two (2) flow point nozzle that can protect a griddle with a maximum cooking area

of 60" (152 cm) wide by 30" (76 cm) deep. The nozzle must be located 10" (61 cm) to 30" (122 cm) above the cooking surface and positioned 0" to 3" (7.6 cm) outside the short side edge of the cooking area of the griddle. This allows the nozzle to be placed anywhere over the short edge and up to 3" (7.6 cm) outside of the short edge of the appliance. The nozzle must be aimed at the point one-quarter the longest side length (1/4L) from the griddle short edge, in-line with the nozzle. See **Figure 3-19b**.

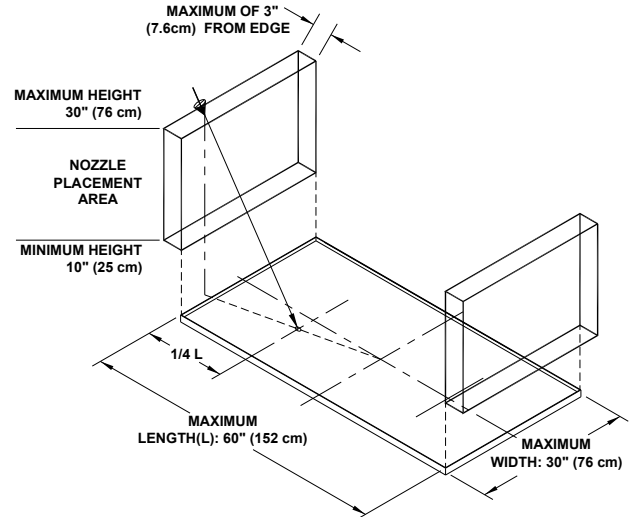

Figure 3-19b.
60" (152 cm) x 30" (76 cm) Griddle
Model N-2W Nozzle

CHARBROILER PROTECTION

Radiant Charbroiler

- Nozzle:** N-1HP (1 Flow Point)
- Coverage:** 36" (91 cm) x 24" (61 cm) Maximum
- Nozzle Ht:** 30" (76 cm) – 48" (122 cm)
- Placement:** Anywhere over the surface of the appliance.
- Aim Point:** Center of appliance.

The **Model N-1HP** nozzle is a one (1) flow point nozzle that can protect a radiant charbroiler with a cooking area of 36" (91 cm) wide by 24" (61 cm) deep. The nozzle must be located 30" (76 cm) to 48" (122 cm) above the cooking surface and positioned anywhere over the cooking area. The nozzle must be aimed at the center of the cooking area. See **Figure 3-20**.

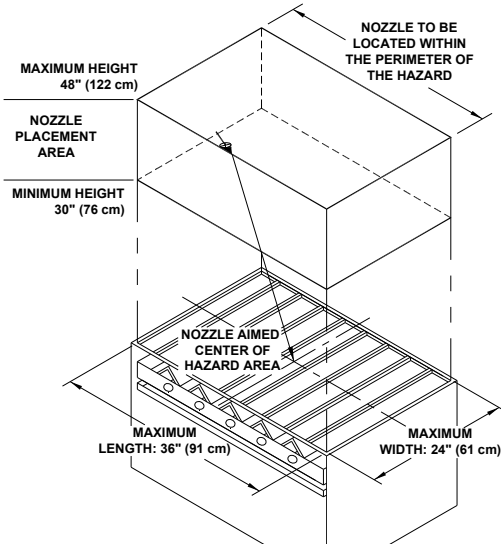

Figure 3-20.
Radiant Charbroiler
Model N-1HP Nozzle

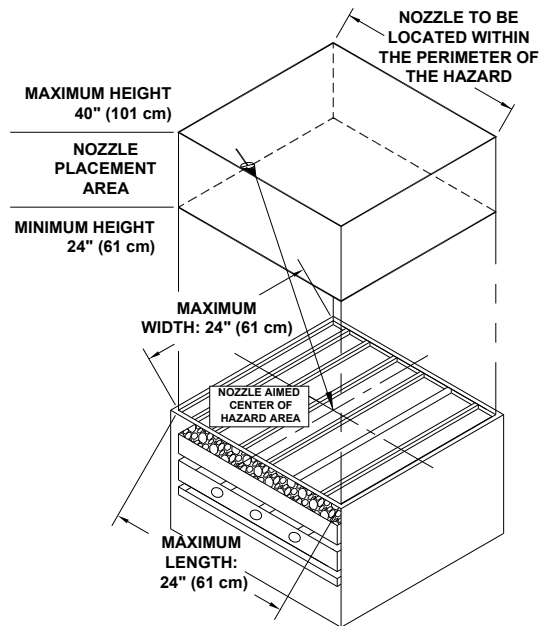

Figure 3-21.
Lava Rock Charbroiler
Model N-2HP Nozzle

Lava Rock Charbroiler Protection

Nozzle: N-2HP (2 Flow Point)

Coverage: 24" (61 cm) x 24" (61 cm) Maximum

Nozzle Ht: 24" (61 cm) – 40" (102 cm)

Placement: Anywhere over the surface of the appliance.

Aim Point: Center of appliance.

The **Model N-2HP** nozzle is a two (2) flow point nozzle that can protect a lava rock charbroiler with a cooking area of 24" (61 cm) wide by 24" (61 cm) deep. The nozzle must be located 24" (61 cm) to 40" (102 cm) above the cooking surface and positioned anywhere over the cooking area. The nozzle must be aimed at the center of the cooking area. See **Figure 3-21**.

Upright Broiler Protection

Nozzle: N-1LP (1 Flow Point)

Coverage: 36" (91 cm) x 24" (61 cm) Maximum

Nozzle Ht: Upper corner of broiling chamber.

Placement: Positioned in the corner of the front opening of the appliance.

Aim Point: Center of cooking grate.

The **Model N-1LP** nozzle is a one (1) flow point nozzle that can protect an upright broiler (salamander broiler) with a cooking area of 36" (91 cm) wide by 24" (61 cm) deep. The nozzle must be located in the top front corner of the broiler and aimed at the center of the cooking grate. See **Figure 3-22**.

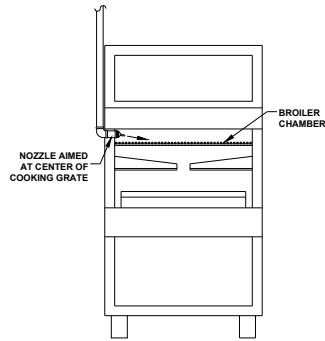

Figure 3-22. Upright Broiler 36" (91 cm) x 24" (61 cm) Model N-1LP Nozzle

Appliances Requiring Multiple Nozzles (Module Protection)

Appliances that exceed the coverage of a single nozzle can be protected with multiple nozzles. The appliance hazard area must be divided into equal sized modules with each module not exceeding the maximum coverage allowed for a single nozzle. Each nozzle is then located and aimed within the module it is protecting, following the limitations stated for single nozzle coverage. See Figure 3-24 for an example of module protection.

CAUTION
The maximum size fryer that can be modularized is 864 square inches (5,574 sq. cm).

This Section Intentionally Blank

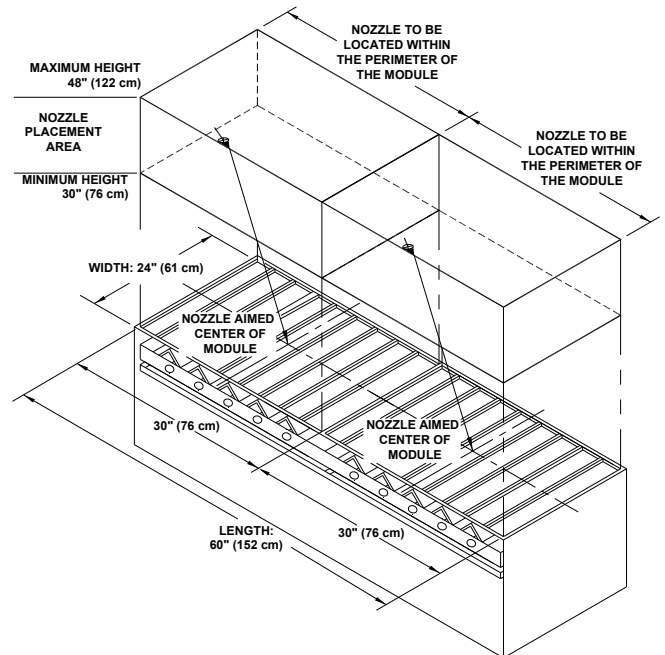

Figure 3-24. Sample Radiant Charbroiler Module Protection



COVERAGE SUMMARY TABLE

APPLICATION	COVERAGE Inches (cm)	NOZZLE	COLOR BAND	FLOW POINT	NOZZLE HT. Inches (cm)	PLACEMENT Inches (cm)	AIMING Inches (cm)	PAGE
DUCT, RECTANGLE	UP TO 50 (127) PER.; MAX. SIDE OF 16-3/4 (43)	N-1LP	RED	1	1-6 (2.5-15) INTO DUCT OPENING	CENTERED IN DUCT	CENTER OF DUCT	3-1
DUCT, SQUARE	UP TO 50 (127) PER.; MAX. SIDE OF 12-1/2 (32)	N-1LP	RED	1	1-6 (2.5-15) INTO DUCT OPENING	CENTERED IN DUCT	CENTER OF DUCT	3-1
DUCT, ROUND	UP TO 50 (127) CIRCUM [16 (41) DIA.]	N-1LP	RED	1	1-6 (2.5-15) INTO DUCT OPENING	CENTERED IN DUCT	CENTER OF DUCT	3-1
DUCT, RECTANGLE	UP TO 150 (381) PER.; MAX. SIDE OF 50 (127)	N-2W	WHITE	2	0-6 (0-15) INTO DUCT OPENING	CENTERED IN DUCT	CENTER OF DUCT	3-1
DUCT, SQUARE	UP TO 150 (381) PER.; MAX. SIDE OF 37-1/2 (95)	N-2W	WHITE	2	0-6 (0-15) INTO DUCT OPENING	CENTERED IN DUCT	CENTER OF DUCT	3-1
DUCT, ROUND	UP TO 150 (381) CIRCUM [47-1/2 (121) DIA.]	N-2W	WHITE	2	0-6 (0-15) INTO DUCT OPENING	CENTERED IN DUCT	CENTER OF DUCT	3-1
PLENUM, SINGLE BANK	12 FT (3.7 m) IN LENGTH; 4 FT (1.2 m) IN WIDTH	N-1HP	BLUE	1	1/3 H FROM TOP; 2 (5) IN FROM FILTER BOTTOM	0-6 (0-15) FROM END	OPPOSITE END OF PLENUM	3-3
PLENUM "V" - BANK	12 FT (3.7 m) IN LENGTH; 4 FT (1.2 m) IN WIDTH	N-1HP	BLUE	1	1/3 H FROM TOP; 1/2 W	0-6 (0-15) FROM END	OPPOSITE END OF PLENUM	3-3
RANGE, TWO-BURNER (Back-shelf) *	12 (30.5) X 24 (61)	N-1LP	RED	1	16 (41) - 30 (76) *	3 (7.6) FROM FRONT OR BACK EDGE ON C'LINE	6 (15) FROM OPPOSITE EDGE ON C'LINE	3-3
RANGE, FOUR-BURNER	24 (61) X 24 (61)	N-1LP	RED	1	30 (76) - 40 (102)	WITHIN 3 (7.6) OF CENTER	CENTER OF APPLIANCE	3-4
RANGE, FOUR BURNER- LOW PROXIMITY (Back-shelf)*	24 (61) X 24 (61)	N-2W	WHITE	2	16 (41) - 30 (76) *	CENTER OF APPLIANCE	CENTER OF APPLIANCE	3-4
RANGE, SIX-BURNER	36 (91) X 24 (61)	N-2LP	YELLOW	2	35 (89) - 43 (109)	CENTER OF APPLIANCE	CENTER OF APPLIANCE	3-4
RANGE/GRIDDLE COMBINATION	30 (76) X 24 (61)	N-1LP	RED	1	30 (76)- 40 (102)	WITHIN 3 (7.6) OF CENTER	CENTER OF APPLIANCE	3-5
RANGE, FOUR BURNER w/B SHELF - HIGH PROXIMITY	24 (61) X 24 (61)	N-2LP	YELLOW	2	30 (76) - 40 (102)	6 (15) OFF FRONT EDGE	6 (15) FROM BACK EDGE	3-6
WOK	12 (30.5) TO 30 (76) DIA.	N-1HP	BLUE	1	30 (76)- 48 (122)	ANYWHERE OVER HAZARD AREA	BOTTOM CENTER	3-6
DEEP FAT FRYER, SINGLE VAT	20.25 (51) X 24 (61)	N-2HP	GREEN	2	24 (61)- 45 (114)	ANYWHERE OVER HAZARD AREA	CENTER OF APPLIANCE	3-7
TILTING SKILLET, BRAISING PAN	20.25 (51) X 24 (61)	N-2HP	GREEN	2	24 (61)- 45 (114)	ANYWHERE OVER HAZARD AREA**	CENTER OF APPLIANCE	3-7
GRIDDLE, STANDARD	42 (107) X 30 (76)	N-1LP	RED	1	24 (61)- 48 (122)	DIRECTLY OVER EDGE OF HAZARD AREA	6 (15) FROM CENTER, IN-LINE WITH NOZZLE	3-7
GRIDDLE, LARGE	48 (122) X 30 (76)	N-1LP	RED	1	30 (76)- 43 (109)	6 (15) OUTSIDE OF SHORTER EDGE OF HAZARD AREA ON C'LINE	3 (7.6) FROM CENTER, IN-LINE WITH NOZZLE	3-8
GRIDDLE, EXTRA LARGE	60 (152) X 30 (76)	N-2LP	YELLOW	2	24 (61)- 48 (122)	DIRECTLY OVER EDGE OF HAZARD AREA	8 (20) FROM CENTER, IN-LINE WITH NOZZLE	3-8
GRIDDLE, STANDARD, EXTRA LOW PROXIMITY	42 (107) X 30 (76)	N-2W	WHITE	2	2 (5) – 10 (25)	OVER ANY CORNER AT A 45° ANGLE TO COOKING SURFACE	AT COOKING SURFACE, EQUAL DISTANCE FROM EDGES	3-9
GRIDDLE, LOW PROXIMITY	60 (152) X 30 (76)	N-2W	WHITE	2	10 (25) – 30 (76)	0" to 3" (7.6 cm) outside the short side edge	1/4 Length of the longest side, in-line with the nozzle	3-9
CHARBROILER, RADIANT	36 (91) X 24 (61)	N-1HP	BLUE	1	30 (76)- 48 (122)	ANYWHERE OVER HAZARD AREA	CENTER OF APPLIANCE	3-9
CHARBROILER, LAVA ROCK	24 (61) X 24 (61)	N-2HP	GREEN	2	24 (61)- 40 (102)	ANYWHERE OVER HAZARD AREA	CENTER OF APPLIANCE	3-10
CHARBROILER, UPRIGHT (SALAMANDER)	36 (91) X 24 (61)	N-1LP	RED	1	UPPER CORNER OF BROILING CHAMBER	FRONT CORNER OF OPENING TO BROILER CHAMBER	CENTER OF COOKING GRATE	3-11

* Coverages can be used when a range with a back-shelf or other type of obstruction, as long as the discharge pattern is not affected.

** Cover must not interfere with nozzle discharge.

*** For the High Proximity Back-shelf coverage the shelf shall not exceed more than 11" (28 cm) over the back edge of the burners and be a minimum of 16" (41 cm) from the top of the appliance.



PIPING LIMITATIONS

This section contains detailed piping limitations that are necessary to design the piping network for The Buckeye Fire Equipment *Kitchen Mister* Fire Suppression System. Because the system is of the pre-engineered type, maximum and minimum piping parameters have already been established for each cylinder size. No variations to these limitations are allowed under the UL Listing.

The maximum and minimum pipe length for each size agent cylinder is based on total internal pipe volume, regardless of the diameter of the pipe used. All piping parameters are based on total system piping and do not make a distinction between branches and supply line piping.

Note: Pipe and fittings must be furnished by the installer. Pipe shall be Schedule 40 black, chrome plated, or stainless-steel pipe. Fittings shall be rated 150 lb (68 kg).

PIPING VOLUME CHART

Allowable Pipe Sizes	Volume Per foot
3/8 in. (17.1 mm OD) pipe	37.5 mL./ft. (123mL/m)
1/2 in. (21.3 mm OD) pipe	59.8 mL./ft. (196mL/m)

Example: 20 feet (6.1 m) of 3/8" (17.1 mm OD) pipe is equal to 750 mL. of pipe volume [20 ft. (6.1 m) X 37.5 mL/ft. (123mL/m) = 750 mL.].

MAXIMUM PIPING PER CYLINDER SIZE

Cylinder Size	Max. Flow Points	Max. Pipe Volume (mL.)	Max. Pipe Vol. Between any two (2) Nozzles. (mL.)
BFR-5	5	1500	1000
BFR-10	10	2500	2000
BFR-15	15	2800*	2500
BFR-20	20	2800*	2500

* Total volume of 3/8" (17.1 mm OD) piping allowed on the BFR-15 or BFR-20 is 2500 mL.

Minimum Piping Requirements

Note: Minimum piping requirements **ONLY** apply when protecting a wok, deep fat fryer, or range.

1. Minimum number of elbows before the closest nozzle protecting a fryer, range, or wok shall be five (5).
2. The minimum piping volume before the closest nozzle protecting a fryer, range, or wok shall not be less than 360 mL.
3. The total system pipe volume shall not be less than 660 mL. for all cylinder sizes.
4. A system shall have a minimum of three (3) flow points.

General Piping Requirements

1. All piping must be either 3/8" (17.1 mm OD) or 1/2" (21.3 mm OD).
2. The maximum number of elbows allowed per system are:

BFR-5:	20 elbows maximum
BFR-10/15/20:	25 elbows maximum
3. The maximum number of elbows between any two nozzles is five (5).
4. The maximum vertical rise of the supply line is 10 feet (3 m), this is either the maximum elevation difference between tank outlet and the highest nozzle or tank outlet and the highest or lowest point in the piping system.
5. The maximum vertical rise of any nozzle above the supply line is 2 feet (0.6 m).
6. No traps are allowed in the piping system.

Note: A "trap" is defined as a section of pipe that would allow liquid to accumulate, such as, either a low point in the piping layout or piping that extends past the last discharge point.
7. When different sized piping is used in the same system, the largest diameter pipe must be closest to the cylinder and sizes are to decrease as they reach the nozzle. So piping always runs from larger to smaller diameter.
8. Elbow(s) or swivel adaptors used at the nozzle for aiming, DO NOT count toward the total elbows allowed per system or the number of elbows between two (2) nozzles.



DETECTOR PLACEMENT

Detectors (fusible links) are required to be placed in the air stream of each appliance (one detector per appliance) and in the opening of the exhaust duct(s) of protected ventilation hoods. Detectors shall be located in the plenum area of the ventilation hood behind the filters, which provide protection for the detection system.

Exhaust Duct Detector Placement

Each exhaust duct must have at least one (1) detector installed. The detector is to be centered in the duct entrance and no more than 12" (30.5 cm) into ductwork.

Cooking Appliance Detector Placement

Each cooking appliance with a continuous cooking surface area of less than 48" (122 cm) x 48" (122 cm) must be protected by one (1) detector. The detector is to be located over the surface of the appliance and in its air stream when the ventilation system is turned on. Cooking appliances with continuous cooking surfaces larger than 48" (122 cm) x 48" (122 cm) must be protected by multiple detectors, using one detector for every 48" (122 cm) x 48" (122 cm) of continuous cooking area.

Exception: If a cooking appliance or appliances are located under a duct opening where a detector has been mounted, it is not necessary to utilize an additional detector as long the duct detector is not more than 12" (30.5 cm) into the duct opening. See **Figure 3-26**.

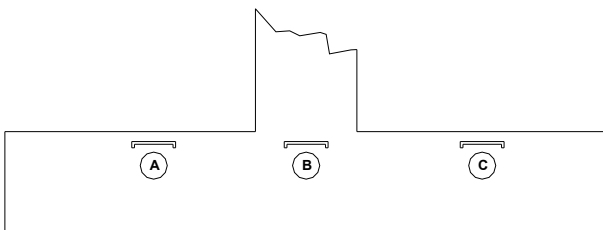

APPLIANCE COVERED BY DETECTOR A	APPLIANCE COVERED BY DETECTOR B	APPLIANCE COVERED BY DETECTOR B	APPLIANCE COVERED BY DETECTOR C
---	---	---	---

Figure 3-26.
Proper Detector Placement
Appliances and Duct



Chapter 4 System Installation

GENERAL

The following chapter will cover the proper installation of the Buckeye Fire Equipment *Kitchen Mister* Fire Suppression System.

This chapter will only cover the various aspects of installation associated specifically with the *Kitchen Mister* System. Additional training in both mechanical and electrical systems is required for proper system installation and training in these areas is solely the responsibility of the distributor.

Various components required for system installation such as pipe, pipe hangers, conduit (EMT), conduit straps, wiring, mounting hardware, and the like are not furnished by Buckeye Fire Equipment and must be provided by the installing distributor.

CAUTION

This technical manual can in no way be considered sufficient to completely understand the proper design, installation, or maintenance of the *Kitchen Mister* System. Buckeye Certified Training is required to become Authorized to perform these procedures. Buckeye Fire Equipment will not be responsible for system(s) designed, installed, or maintained by individuals or companies not trained and Authorized by Buckeye Fire Equipment.

CYLINDER INSTALLATION

Before attempting cylinder installation, it is important to assure that you have the correct bracket assembly for the selected cylinder:

<u>Cylinder</u>	<u>Bracket Assembly</u>
BFR-5	Model MB-1
BFR-10/15/20	Model MB-2

WARNING

The cylinder valve assembly is shipped with an anti-recoil plate covering the discharge outlet. The anti-recoil plate must remain in place until the discharge piping is connected to the valve.

The cylinder must be vertically mounted. See **Figure 4-1**.

1. The wall used to mount the cylinder must be sufficiently strong to support the cylinder weight.
2. Mount the bracket using lag bolts, making sure it is level.
3. Loop the cylinder strap loosely over the top of the cylinder as shown below.
4. Hook the bottom rim of the cylinder into the bracket.
5. Allow the mounting strap provided to slide into the two top grooves of the bracket and around the cylinder.
6. Tighten the strap securely around the cylinder.

The bracket cannot be fastened to dry wall or other such material, if this type of wall is encountered a stud must be located and the bracket fastened to it.

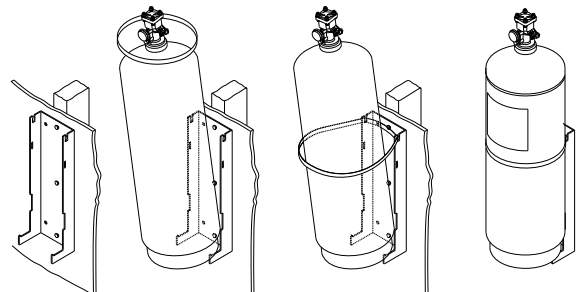

Figure 4-1.
Cylinder and Mounting Bracket Installation

Pipe and Nozzle Installation

Any foreign substance left in the piping network (i.e., cutting oil, dirt, metal shavings, etc.) have the potential to clog the nozzles upon system discharge. For this reason, all pipe must be thoroughly cleaned before installation. The following procedure should be used when installing piping and nozzles:

1. Check pipe threading dies to assure that they are cutting properly.
2. After cutting, all pipes sections are to be reamed and the pipe cleaned.
3. Teflon tape shall be used for all pipe connections. Starting at the SECOND thread from the end, wrap



the tape clockwise around the threads working away from the pipe opening.

4. DO NOT over-tighten piping, using a pipe wrench make sure all piping is snug.
5. If a section of pipe is over-tightened, it must be completely removed, the Teflon tape must be removed and re-applied, and the section be reinstalled.
6. Make sure all piping is secure by using the appropriate pipe hangers and/or straps.
7. Before installing nozzles, blow all piping out with dry air or nitrogen to assure no foreign material is left in the piping system.
8. Install all nozzles in accordance with **Chapter 3** of this manual.
9. Be sure that the blow off cap provided with each nozzle is in place.

Note: Make sure to explain to the owner of the system the importance of nozzle caps (i.e., to keep debris out of the nozzle and prevent clogging) and that they should be checked daily to assure they are in place

SYSTEMS RELEASING MODULE(S) INSTALLATION

Mounting Systems Releasing Module(s) Directly to Cylinder Valve

Any of the Systems Releasing Module(s) (**Model SRM2-M, SRM2-E-24, SRM2-E-120, SRM and SRM-D**) can be installed directly onto the cylinder valve if desired. Four mounting screws are required for fastening the Systems Releasing Module(s) to the top of the cylinder valve; these screws are provided with the Systems Releasing Module(s).

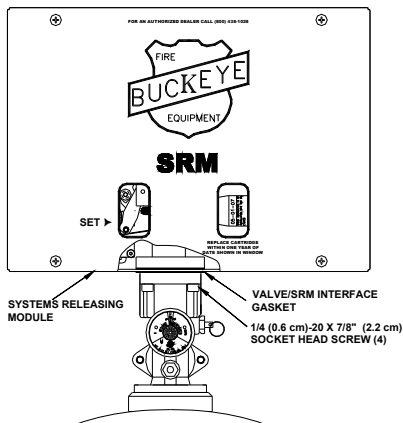

Figure 4-2.

**Systems Releasing Module(s) Mounted
Directly to Cylinder Valve (Model SRM Shown).**

After mounting the cylinder, align the mounting holes in the control head base with the holes in the cylinder valve.

When installing the SRM & SRM-D the interface gasket must be undamaged and in positioned so that all the holes in the gasket align with the holes in the manifold block. With the interface gasket in place and using all four mounting screws provided, mount the Systems Releasing Module(s) firmly onto the cylinder valve using a 3/16" (0.5 cm) Allen wrench. See **Figure 4-2**.

For all SRM2 releasing modules verify that O-ring is not damaged and installed properly on the O-ring groove of the manifold block of the control head. With the mounting holes aligned correctly insert the SRM2 mounting block into the cylinder valve body and secure with the four (4) mounting screws provided.

Wall Mounting of Systems Releasing Module(s)

Any of the Systems Releasing Module(s) (**Model SRM2-M, SRM2-E-24, SRM2-E-120, SRM and SRM-D**) can be wall mounted and used to pneumatically actuate a maximum of five (5) agent cylinders.

For remote cylinder actuation, the Systems Releasing Module(s) must be mounted directly to a wall using four screws (not included). The four plugs in the back wall of the Systems Releasing Module(s) must be removed and the resulting holes used to secure the unit to the desired wall. No additional bracket is required for mounting the Systems Releasing Module(s) in this manner.

After firmly mounting the Systems Releasing Module(s) to a wall, a **Model BFR-CAP** Valve Cap Assembly (ordered separately) must be installed on all agent cylinders being remotely actuated. Four mounting screws are provided with the Valve Cap Assembly for fastening the Valve Cap Assembly to the top of the cylinder valve. A 3/16" (0.5 cm) Allen wrench is required for tightening the mounting screws. The Systems Releasing Module(s) is then connected to each agent cylinder using 1/4" (0.6 cm) OD copper tubing.

Option #1: Single Cylinder Activation

1. The (4) mounting screw holes in the bottom of the Systems Releasing Module(s) must be filled. The Systems Releasing Module(s) Connection Kit includes four (4) 1/4 (0.6 cm)-20 x 7/8 (2.2 cm) socket head screws to accomplish this. See **Figure 4.3**.
2. Install the 1/8" NPT – 1/4" Tubing adapter into the 1/8" NPT threaded discharge port located in the bottom of the SRM manifold block.
3. Mount the Systems Releasing Module(s) to a wall as described above.
4. Mount the agent cylinder making sure not to exceed the maximum length of tubing allowed.



5. Install a **Model BFR-CAP** Valve Cap Assembly on the agent cylinder valve.
6. Connect the Systems Releasing Module(s) to the agent cylinders using 1/4" (0.6 cm) OD copper tubing.

Limitations for Remote Cylinder Actuation

Number of Cylinders	Maximum Length Of 1/4" (0.6 cm) Copper Tubing	Actuation Cartridge Required
1 – 3	15 feet (4.6 m) †	BFR-AC-S*
1 – 5	25 feet (7.6 m) †	BFR-AC-L**
1 - 3	100 feet (30.5 m) ††	BFR-AC-L**

* Included with Systems Releasing Module(s)

** Sold separately

† The maximum length of tubing allowed between agent cylinders is 3 feet (0.9 m).

†† The maximum length of tubing allowed between agent cylinders is 100 feet (30.5 m).

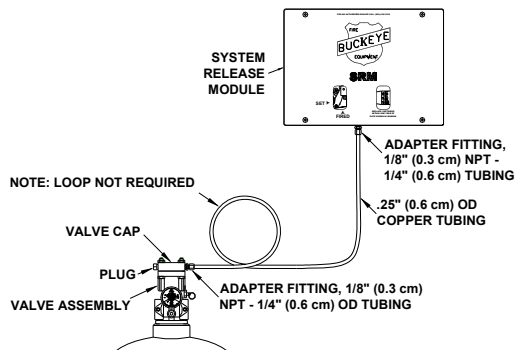

Figure 4-3.

Systems Releasing Module(s) Shown Actuating a Single Agent Cylinder (SRM Shown)

Note: Refrigeration type copper tubing is used for remote cylinder actuation. This tubing shall have an outside diameter or 1/4" (0.6 cm) and a minimum wall thickness of 1/32" (0.08 cm).

Option #2: Multiple Cylinder Actuation

1. The (4) mounting screw holes in the bottom of the Systems Releasing Module(s) must be filled. The Systems Releasing Module(s) Connection Kit includes four (4) 1/4 (0.6 cm)-20 x 7/8" (2.2 cm) socket head screws to accomplish this. See **Figure 4.4**.
2. Mount the Systems Releasing Module(s) to a wall as described above.
3. Mount the agent cylinder making sure not to exceed the maximum length of tubing allowed.
4. Install a **Model BFR-CAP** Valve Cap Assembly on each agent cylinder valve.
5. Replace the plug in one side of the valve cap with the 1/8" (0.3 cm) NPT - 1/4" (0.6 cm) OD tube adapter fitting provided for all but **the last agent cylinder** in line. The Valve Cap Assembly used with the last agent cylinder valve is not changed.

Note: Refrigeration type copper tubing is used for remote cylinder actuation. This tubing shall have an outside diameter or 1/4" (0.6 cm) and a minimum wall thickness of 1/32" (0.08 cm).

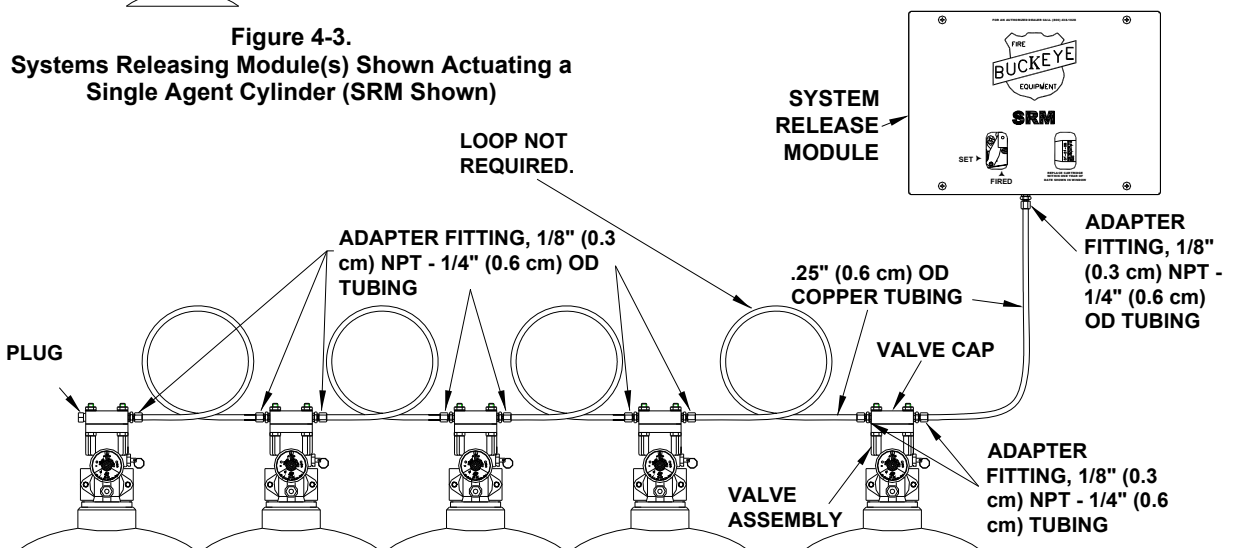

Figure 4-4.

Multiple Cylinder Actuation Using the Systems Releasing Module(s) (SRM Shown)



BUCKEYE SHIELDED CABLE INSTALLATION OVERVIEW

Buckeye Shielded Cable is flexible conduit with a 1/16" (0.16 cm) stainless steel cable core that can be used for all system inputs and outputs (fusible link line, gas valve line, and remote pull station line) instead of using conduit and corner pulleys.

Note: If Buckeye Shielded Cable is not used for system controls, a combination of Buckeye Shielded Cable and 1/2" (1.3 cm) EMT conduit with corner pulleys or just 1/2" (1.3 cm) EMT conduit and corner pulleys are also approved.

In general, Buckeye Shielded Cable is attached at one end to the Systems Releasing Module(s) with a Buckeye Shielded Cable Interface, run to where it needs to be terminated (hood, gas valve, or pull station), and connected at the other end with another Buckeye Shielded Cable Interface. See **Figure 4-5**.

The Shielded Cable Interface holds the outer flexible conduit and allows the 1/16" (0.16 cm) stainless steel cable to pass through. It connects to any standard 1/2" (1.3 cm) conduit type connection fitting, such as a corner pulley or conduit connector.

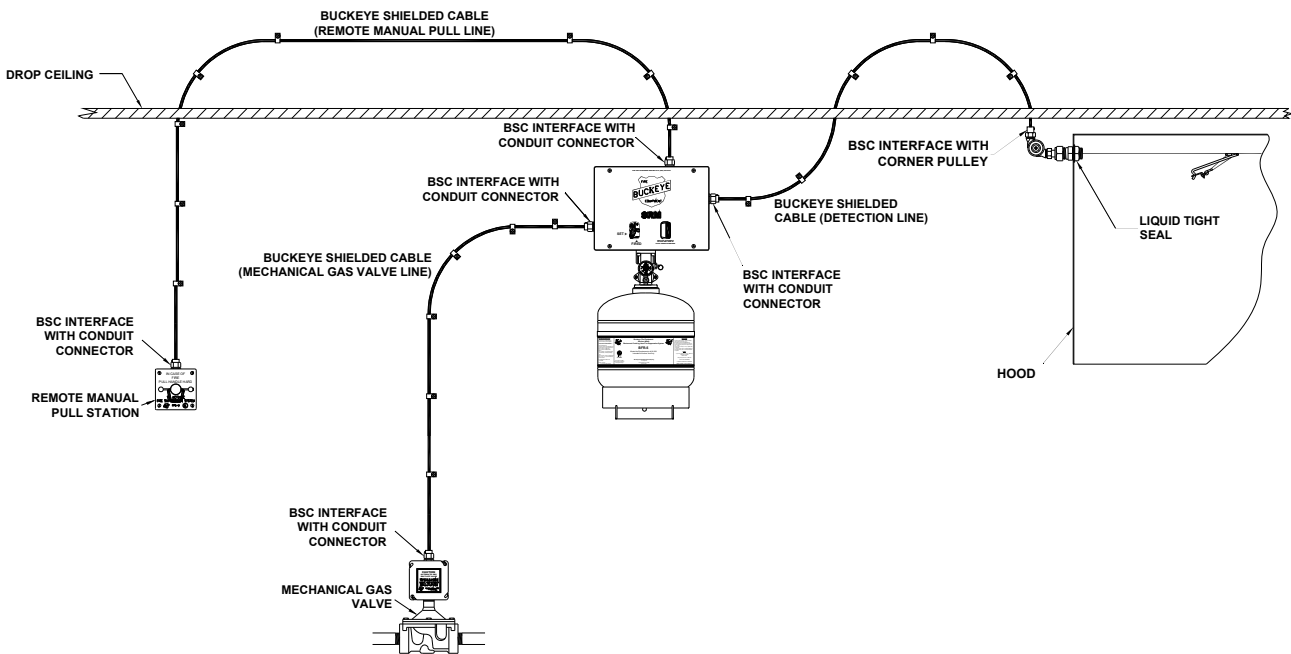

Figure 4-5.
Buckeye Shielded Cable Installation
Typical Installation



Buckeye Shielded Cable Installation Guidelines

Buckeye Shielded Cable (Patent Pending) can be used for all system mechanical interfaces:

- Fusible Link Detection Line
- Gas Valve Line
- Remote Mechanical Pull Station Line

The **Model BFR-SC-100** comes with 105 feet (32 m) of flexible conduit with 210 feet (64 m) of 1/16" (0.16 cm) stainless steel cable inside it. See **Figure 4-6**.

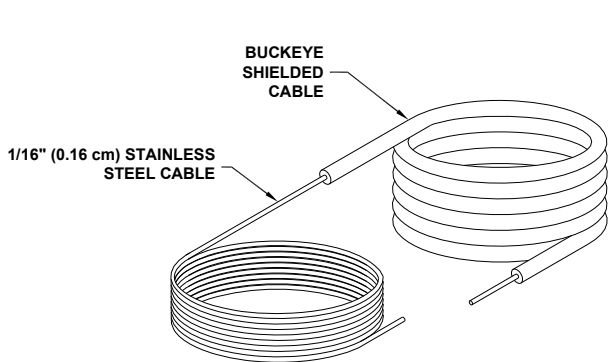

Figure 4-6.
Buckeye Shielded Cable

To install Buckeye Shielded Cable follow these guidelines:

1. Determine which input or output lines Buckeye Shielded Cable will be used for:
 - Fusible Link Detection Line
 - Gas Valve Line
 - Remote Pull Station Line
2. Mount the Buckeye Shielded Cable to either end of the line and run the cable in the manner it will be installed, either back to the Systems Releasing Module(s) or to the termination device (plenum, gas valve, or pull station).
3. BSC must be securely mounted with a clip or tie-down at least every four (4) feet (1.2 m).
4. Pull enough 1/16" (0.16 cm) stainless steel cable through the terminated end to allow for termination at **BOTH** ends of the line.

Example: When connecting a gas valve to the control head with Buckeye Shielded Cable, first connect the cable to the gas valve using a Buckeye Shielded Cable

Interface, then run the cable back to the Systems Releasing Module(s). Then, pull enough of the 1/16" (0.16 cm) stainless steel cable through the gas valve side of the cable to allow for connection of **BOTH** the gas valve (at one end) and the Systems Releasing Module(s) (at the other end).

5. The Buckeye Shielded Cable can now be cut at the end opposite of where the excess 1/16" (0.16 cm) stainless steel cable has been pulled through. To cut the cable, use a sharp, heavy duty, cable cutter and cut through the entire piece of Buckeye Shielded Cable, both the outer flexible conduit and the inner cable, at the location desired. See **Figure 4-7**.

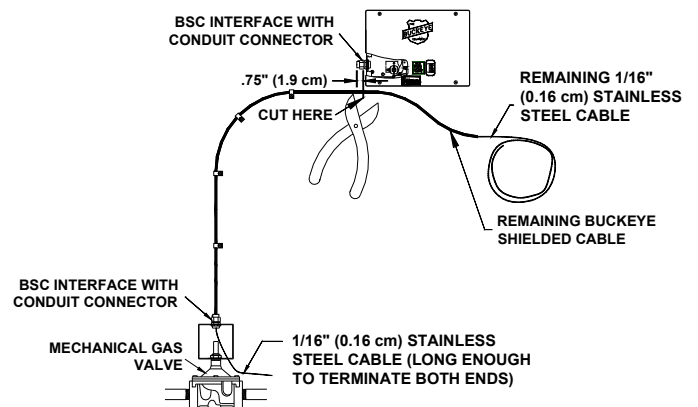

Figure 4-7.
Cutting Buckeye Shielded Cable

Note: Buckeye Shielded Cable must **ALWAYS** be cut complete with the 1/16" (0.16 cm) stainless steel cable inside the outer flexible conduit.

6. Push the 1/16" (0.16 cm) stainless steel cable back through the flexible conduit until there is enough on both ends to make proper terminations.
7. The stainless-steel cable can then be used for connection to Systems Releasing Module(s), pull station, gas valve, or fusible link line.

Minimum Bend Radius – Buckeye Shielded Cable

When installing Buckeye Shielded Cable the minimum acceptable bend radius is 9" (23 cm) and each bend must be preceded and followed by at least 1 foot (.3 m) of straight cable run. See **Figure 4-8**.

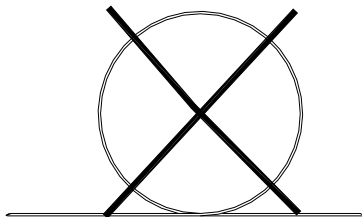
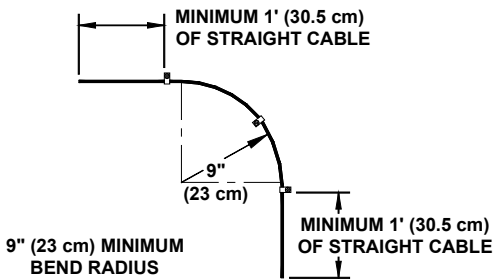

DO NOT COIL OR LOOP BSC

Figure 4-8.
Buckeye Shielded Cable Minimum Bend Radius

Note: A minimum of three (3) clips or tie-downs shall be used to secure all bends as shown.

CAUTION

Buckeye Shielded Cable CAN NOT be looped or coiled during installation. After a cable bend a minimum of one foot of straight cable is required. Excess cable must be cut off and not looped or coiled.

Buckeye Shielded Cable Interface Installation

The Buckeye Shielded Cable Interface is required for connecting Buckeye Shielded Cable to 1/2" (1.3 cm) EMT conduit type fittings, such as 1/2" (1.3 cm) EMT conduit connectors and corner pulleys.

To connect Buckeye Shielded Cable to the Shielded Cable Interface, simply insert the outer flexible conduit into the larger opening on one side of the Shielded Cable Interface, tighten the set screw (using a 3/32" (0.24 cm) hex wrench), and push the 1/16" (0.16 cm) stainless steel cable through the smaller opening on the other side. See **Figure 4-9.**

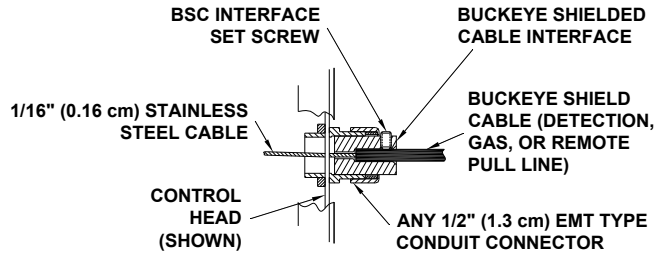

Figure 4-9.
Buckeye Shielded Cable Interface Installation Detail

After installing the Shielded Cable Interface, it can now be attached to any standard 1/2" (1.3 cm) EMT conduit type connection, corner pulleys, and 1/2" (1.3 cm) EMT conduit unions. The 1/16" (0.16 cm) cable can then be connected to the desired mechanism (i.e., the SRM ratchet, the gas valve, fusible links, and mechanical pull station to name a few). See **Figure 4-10.**

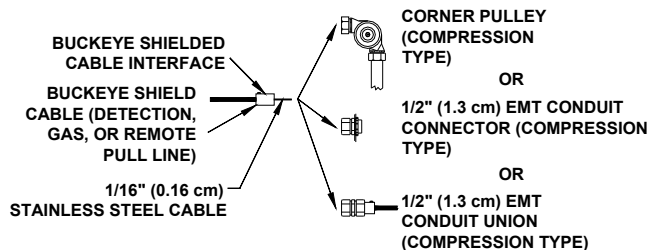

Figure 4-10.
Buckeye Shielded Cable Interface Typical Connection Types



Fusible Link Line Installation Overview

In general, fusible links are installed in the plenum area of the ventilation hood and connected to the Systems Releasing Module(s) (**Models: SRM2-M, SRM-D and SRM Only**) using stainless steel cable. This cable is kept under tension by the Systems Releasing Module(s) until a fusible link separates, actuating the suppression system.

The following methods are approved for the installation of the fusible link detection line:

Method #1:

- Buckeye Shielded Cable used to connect the Systems Releasing Module to the plenum.
- No fusible link brackets or conduit used in the plenum area.
- Approved with or without the use of Fusible Link Holders.

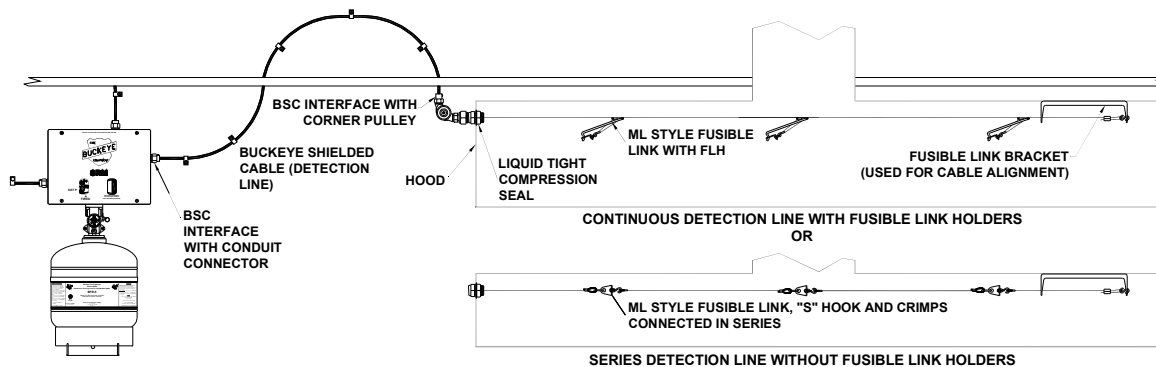

Figure 4-11.
Fusible Link Line Installation Method #1

Method #2:

- Buckeye Shielded Cable used to connect the Systems Releasing Module(s) to the plenum.
- Fusible link brackets and conduit used in plenum area.
- Approved with or without the use of Fusible Link Holders.

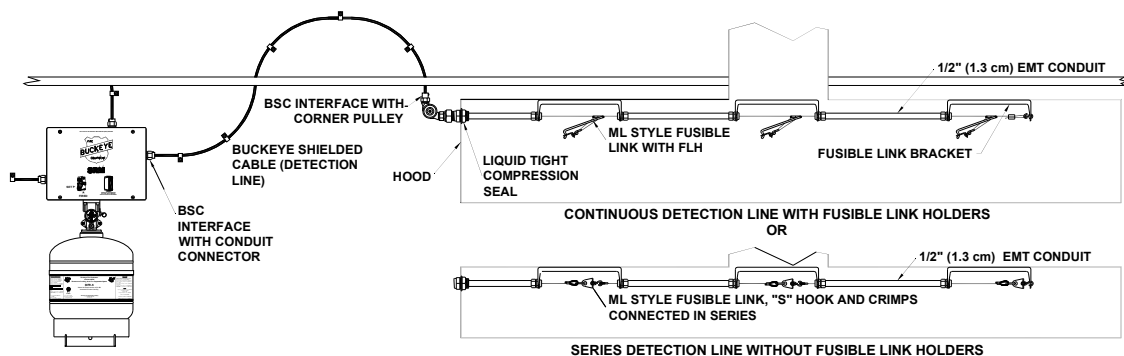

Figure 4-12.
Fusible Link Line Installation Method #2



Method #3:

- 1/2" (1.3 cm) EMT conduit and Buckeye Corner Pulleys used to connect the Systems Releasing Module(s) to the plenum.
- No fusible link brackets or conduit used in the plenum area.
- Approved with or without the use of Fusible Link Holders (only shown with holders used).

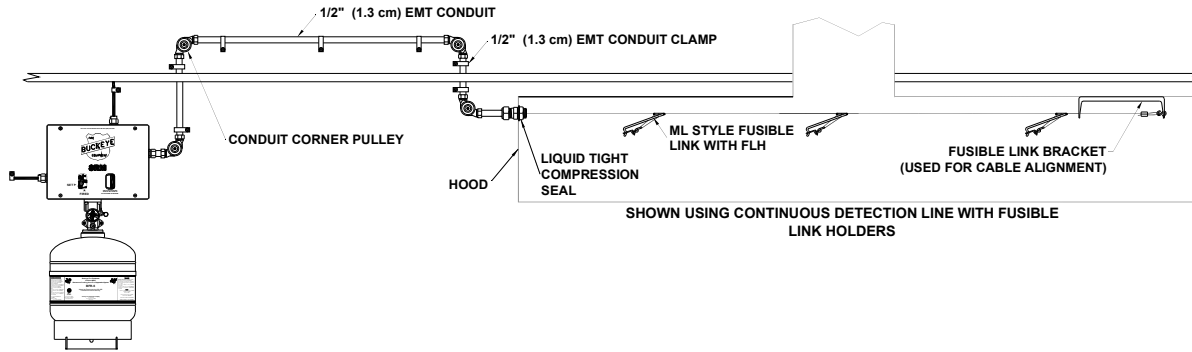

Figure 4-13.
Fusible Link Line Installation Method #3

Method #4:

- 1/2" (1.3 cm) EMT conduit and Buckeye Corner Pulleys used to connect the Systems Releasing Module(s) to the plenum.
- Fusible link brackets and conduit used in plenum area.
- Approved with or without the use of Fusible Link Holders (only shown with holders used).

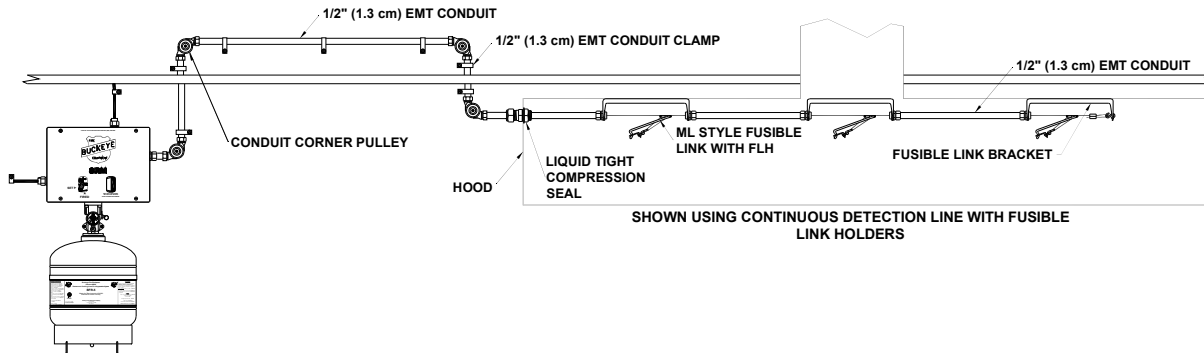

Figure 4-14.
Fusible Link Line Installation Method #4



Method #5:

- 1/2" (1.3 cm) EMT conduit and Buckeye Corner Pulleys used in combination with Buckeye Shielded Cable to connect the Systems Releasing Module(s) to the plenum.
- No fusible link brackets or conduit used in the plenum area.
- Approved with or without the use of Fusible Link Holders (only shown with holders used).

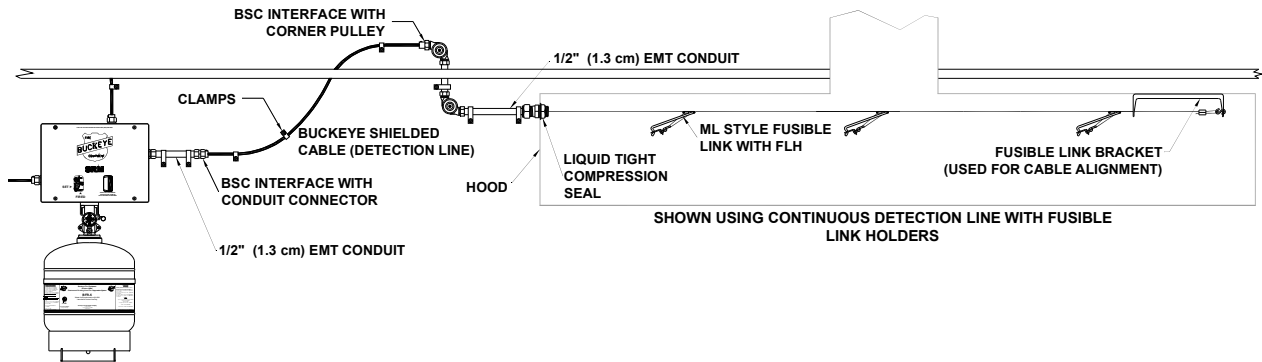

Figure 4-15.
Fusible Link Line Installation Method #5

Method #6:

- 1/2" (1.3 cm) EMT conduit and Buckeye Corner Pulleys used in combination with Buckeye Shielded Cable to connect the Systems Releasing Module(s) to the plenum.
- Fusible link brackets and conduit used in plenum area.
- Approved with or without the use of Fusible Link Holders (only shown with holders used).

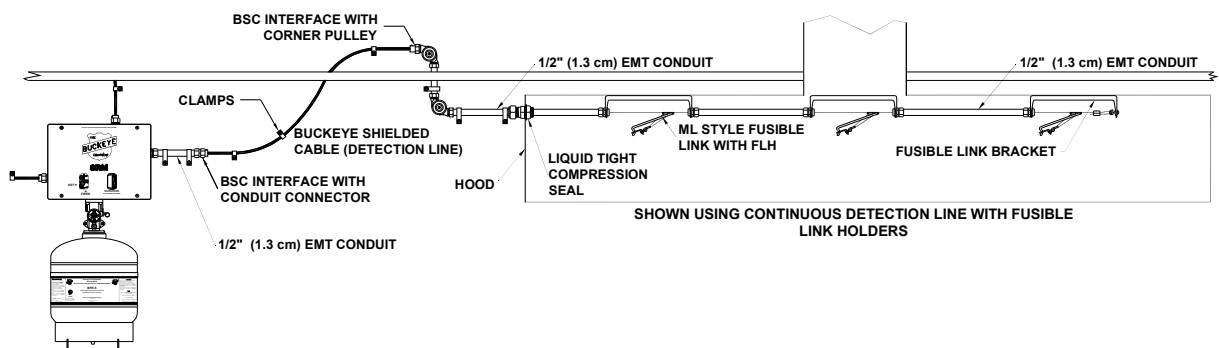

Figure 4-16.
Fusible Link Line Installation Method #6



Fusible Link Line Installation

NOTE: Fusible Link Line installation only applies to mechanically operated Systems Releasing Module(s) (**Models: SRM2-M, SRM-D and SRM**)

Fusible link line limitations are based on the method by which the Systems Releasing Module(s) is connected to the plenum. Limitations are as follows:

Fusible Link Line Limitations

1. Conduit and corner pulleys used with standard 1/16" (0.16 cm) stainless steel cable to connect Systems Releasing Module(s) to plenum:

Max. No. of Detectors:	20
Max. Length of Conduit:	150 feet (45.7 m)
Max. No. of Corner Pulleys:	35

2. ONLY Buckeye Shielded Cable used to connect Systems Releasing Module(s) to plenum:

Max. No. of Detectors:	10
Max. Length of BSC:	35 feet (10.7 m)
Max. No. of Bends:	6

3. Conduit and corner pulleys with standard 1/16" (0.16 cm) stainless steel cable in combination with Buckeye Shielded Cable used to connect Systems Releasing Module(s) to plenum:

Max. No. of Detectors:	10
Max. Length of Conduit:	25 feet (7.6 m)
Max. No. of Corner Pulleys:	8
Max. Length of Buckeye Shielded Cable:	35 feet (10.7 m)
Max. No. of Bends in BSC:	6

Note: The use of Fusible Link Holders in the plenum area does not affect fusible link line limitations.

Globe ML Style fusible links are used for automatic actuation of the *Kitchen Mister* System and must be installed in the plenum area of the ventilation hood (for proper link placement see **Chapter 3** of this manual).

Fusible Link Line Installation Step #1:

Determine if fusible link brackets and conduit will be used in the plenum area:

The *Kitchen Mister* System is approved:

1. With conduit and fusible link brackets in the plenum area.

2. Without fusible link brackets and conduit in the plenum area when filters are present, thus providing mechanical protection for the fusible link line.

If fusible link brackets and conduit are used in plenum area:

Although fusible link brackets and conduit are only required for applications where no filters are present in the ventilation hood, they can be used for all applications if desired.

Once the decision has been made to use fusible link brackets and conduit in the plenum area, begin by installing the detector brackets in the plenum area of the ventilation hood over each appliance and in each duct opening as described in **Chapter 3** of this manual. Connect the fusible link brackets using 1/2" (1.3 cm) EMT conduit and conduit connectors.

A Buckeye corner pulley is required for each change in conduit direction. The conduit will exit the plenum area through an approved liquid tight hood seal. The detection line can now be run back to the Systems Releasing Module(s).

If fusible link brackets and conduit are not used in plenum area:

For installations where filters are present in the ventilation hood, fusible link brackets and conduit **ARE NOT** required in the plenum area.

Install a single bracket at the top of the far end of the plenum, approximately 3 inches (7.6 cm) in from the far wall and in line with the center of the duct opening.

This bracket is not used to center a fusible link, but rather as a termination point for the fusible link line cable.

After mounting the terminal bracket, use another bracket as a template, making sure it is also in line with the duct centerline, to determine the location of the hood penetration on the other end of the plenum. Install an approved liquid tight hood seal in the hole in the far end of the hood. See **Figure 4-17**.

The terminal bracket is the only bracket required for this application. The fusible links will be attached directly to the detection line in the plenum area in their appropriate locations (see **Chapter 3** for proper fusible link placement). No additional brackets are required. The detection line can now be run back to the Systems Releasing Module(s).

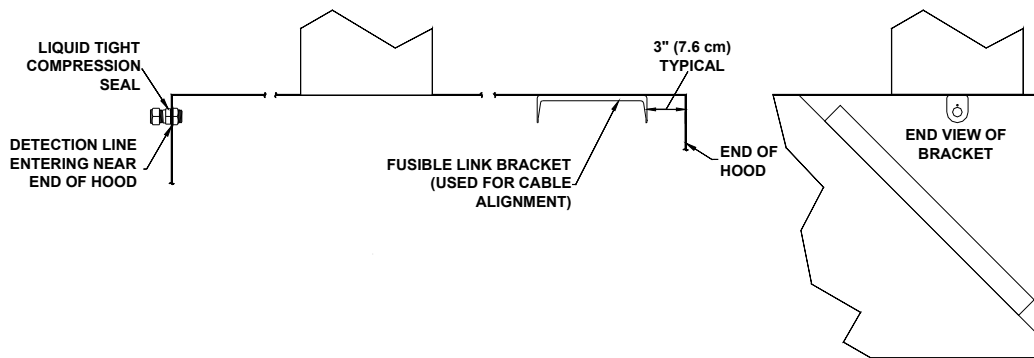

Figure 4-17.
Terminal Bracket Installation
For Systems without Brackets or
Conduit in Plenum Area

Fusible Link Line Installation Step #2:

Determine how the fusible link line will be connected to the Systems Releasing Module(s) from the plenum:

There are three (3) approved methods by which the fusible link detection line can be run from the Systems Releasing Module(s) to the plenum, they are:

1. Using standard 1/2" (1.3 cm) EMT conduit and a corner pulley for each change in direction.
2. Using ONLY Buckeye Shielded Cable.
3. Using a combination of Buckeye Shielded Cable and 1/2" (1.3 cm) EMT conduit / corner pulleys.

Note: Buckeye Shielded Cable CANNOT be attached directly to the hood penetration device used to seal the plenum area, a corner pulley and/or six (6) inches (15 cm) of standard 1/2" (1.3 cm) EMT conduit must be placed in between the Buckeye Shielded Cable Interface and the plenum.

OPTION #1: Using 1/2" (1.3 cm) EMT Conduit and Corner Pulleys

1/2" (1.3 cm) EMT conduit can be used to connect the fusible link line in the plenum area to the Systems Releasing Module(s). A Buckeye corner pulley is required whenever a change in conduit direction is necessary.

The conduit is connected to the Systems Releasing Module(s) through a knockout in the upper right-side corner. 1/16" (0.16 cm) stainless steel cable can now be run through the conduit system from the Systems Releasing Module(s) to the plenum area.

OPTION #2: Using only Buckeye Shielded Cable

Buckeye Shielded Cable can be used to connect the fusible link line in the plenum area to the Systems Releasing Module(s). When using this option, only the stainless-steel cable that comes with Buckeye Shielded Cable can be used.

Note: Refer to the Buckeye Shielded Cable Installation Guidelines section of this chapter for details.

The Buckeye Shielded Cable is connected to the Systems Releasing Module(s) through a knockout in the upper right-side corner. Install a standard conduit connector in the knockout hole. Then connect a Buckeye Shielded Cable Interface to the end of the section of Buckeye Shielded Cable to be used. Connect the Buckeye Shielded Cable Interface to the conduit connector installed in the knockout. The Buckeye Shielded Cable can then be run to the plenum area.

Note: A corner pulley and/or six (6) inches (15 cm) of standard 1/2" (1.3 cm) EMT conduit is required between the Buckeye Shielded Cable and the liquid tight seal installed in the plenum.

OPTION #3: Using a Combination of Buckeye Shielded Cable and Conduit and Corner Pulleys

Buckeye Shielded Cable can be used in combination with 1/2" (1.3 cm) EMT conduit to connect the fusible link line in the plenum area to the Systems Releasing Module(s).

Note: Refer to the Buckeye Shielded Cable Installation Guidelines section of this chapter for details.



For all portions of the detection line that use conduit instead of Buckeye Shielded Cable, a Buckeye Corner Pulley is required whenever a change in conduit direction is necessary.

CAUTION

A corner pulley and/or six (6) inches (15 cm) of standard 1/2" (1.3 cm) EMT conduit is required between the Buckeye Shielded Cable and the liquid tight seal installed in the plenum.

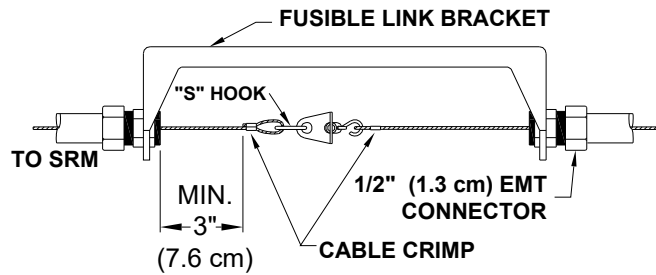

Figure 4-19.
Series Link Installation

Fusible Link Line Installation Step #3:

Installing the fusible links in the plenum area:

Fusible links can be installed in the plenum area of the ventilation hood either with or without the use of Buckeye **Model FLH-1** Fusible Link Holders.

Note: A minimum of three inches of travel towards the SRM must be maintained between a conduit connector and the cable crimp or fusible link holder.

OPTION #1: Installing fusible links when fusible link brackets and conduit ARE used:

When fusible link brackets and conduit are used in the plenum area, attach the terminal link to the far end of the fusible link with an "S" Hook (see **Figure 4-18**). The "S" Hook should be crimped closed after installation.

After installing the terminal link, a tight loop is then made in the cable and secured with the crimp provided. It is attached to the other end of the terminal link and fed through the conduit to the next bracket. This cable is then used to connect the remaining series links. Each link must be centered in the detector bracket. See **Figure 4-19**.

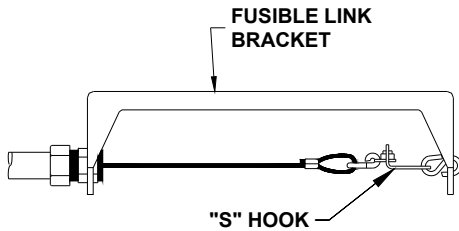

Figure 4-18
Terminal Link Installation

After the last link is connected, the control head can be put in the set position as described in the next section of this chapter.

Fusible Link Installation Using Fusible Link Holders:

If Buckeye Fusible Link Holders are used, make sure to leave 4" (10 cm) of slack in the fusible link line cable per fusible link. This method is recommended because it requires fewer cuts and crimps in the fusible link line and allows fusible links to be easily moved to assure they are in the correct position.

Attach the fusible link line to the terminal bracket by making a tight loop in the fusible link cable and securing it with the crimp provided. This loop is then connected to the far end of the terminal bracket using an "S" Hook. The "S" Hook should be crimped closed after installation. See **Figure 4-20**.

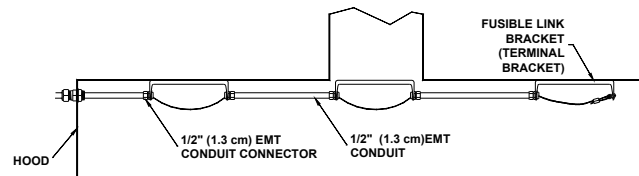

Figure 4-20.
Terminal Bracket Connection

Fusible Link Holders can now be installed starting at the terminal bracket and working toward the Systems Releasing Module(s). This is accomplished by looping the cable through the opening in the Fusible Link Holder and hooking the fusible link on the loop. See **Figure 4-21**.

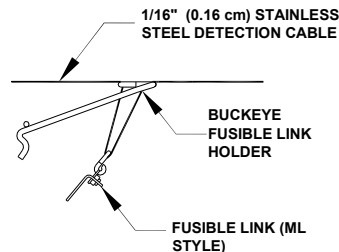

Figure 4-21.
Fusible Link Connection

The hole in the fusible link can now be hooked onto the bottom of the holder as shown in **Figure 4-22**.

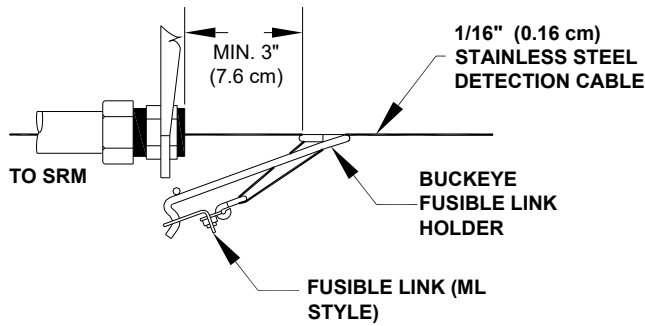

Figure 4-22.
Fusible Link Holder Connection

Fusible links can be positioned by sliding the Fusible Link Holder along the detection line before it is completely tensioned to the desired position.

After the last link is connected, the Systems Releasing Module(s) can be put in the set position as described in the next section of this chapter.

OPTION #2: Installing fusible links when fusible link brackets and conduit ARE NOT used:

When fusible link brackets and conduit are NOT used in the plenum area, begin the fusible link installation at the terminal bracket which has already been installed.

The detection line is run through the hood quick seal, through the larger hole in the near end of the terminal bracket and attached to the far end of the terminal bracket using an “S” Hook. The “S” Hook should be crimped closed after installation. See **Figure 4-23**.

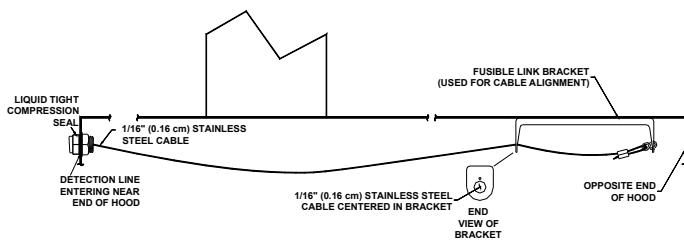

Figure 4-23.
Fusible Link Line Termination in Plenum

Starting at the far end of the plenum, determine the location of the first fusible link (for proper link placement see **Chapter 3** of this manual), cut the cable at the desired location and install the first fusible link as shown in **Figure 4-24**.

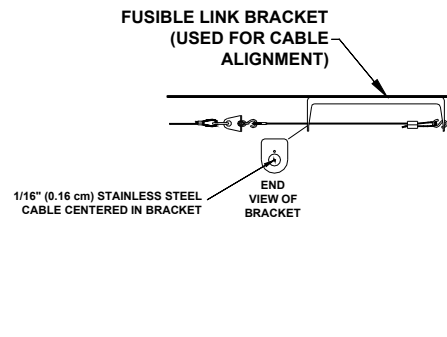

Figure 4-24.
Fusible Link Connection

This cable is then used to connect the remaining series links. Repeat the above procedure until all the links are in their desired locations. See **Figure 4-25**.

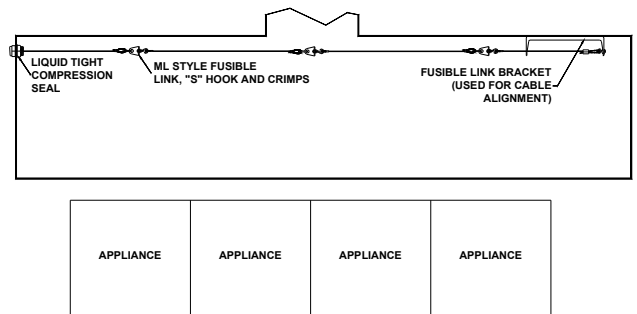

Figure 4-25.
Typical Fusible Link Installation

Fusible Link Installation Using Fusible Link Holders:

If Buckeye Fusible Link Holders are used, make sure to leave 4” (10 cm) of slack in the fusible link line cable per fusible link. This method is recommended because it requires fewer cuts and crimps in the fusible link line and allows fusible links to be easily moved to assure they are in the correct position.

Begin the fusible link installation at the terminal bracket which has already been installed.

Note: Fusible links are typically not centered in this bracket. This bracket is usually used for cable termination and centering only.

The detection line is run through the hood quick seal, through the larger hole in the near end of the terminal bracket and attached to the far end of the terminal bracket using an “S” Hook. The “S” Hook should be crimped closed after installation. See **Figure 4-26**.

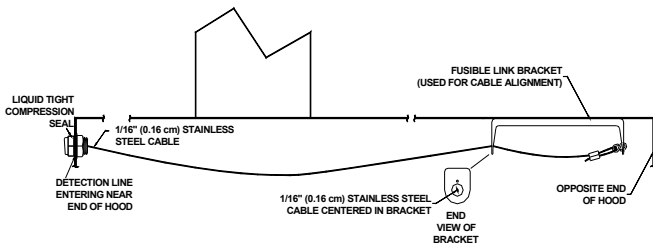

Figure 4-26.
Fusible Link Line Installation

Fusible Link Holders can now be installed starting at the terminal bracket and working toward the Systems Releasing Module(s). This is accomplished by looping the cable through the opening in the Fusible Link Holder and hooking the fusible link on the loop. See **Figure 4-21**.

The hole in the fusible link can now be hooked onto the bottom of the holder as shown in **Figure 4-22**.

Fusible links can be positioned by sliding the Fusible Link Holder along the detection line before it is completely tensioned to the desired position.

After the last link is connected, the Systems Releasing Module(s) can be put in the set position as described in the next section of this chapter.

Note: The system is approved for use with or without the use of fusible link holders. Buckeye Fire Equipment recommends their use to minimize the number of connections made in the fusible link system thus lessening the possibility of unwanted discharges

Remote Pull Station Installation

The **Model RPS-M** Remote Mechanical Pull Station or **Model RPS-M-RM** Remote Mechanical Pull Station Recessed Mount must be used for remote actuation of the Buckeye *Kitchen Mister* System. They are to be located near an exit in the path of egress from the hazard area and no more than 48 inches above the floor. They can be connected to the Systems Releasing Module(s) as follows:

1. Using standard 1/2" (1.3 cm) EMT conduit and a corner pulley for each change in direction.
2. Using **ONLY** Buckeye Shielded Cable.
3. Using a combination of Buckeye Shielded Cable **and** 1/2" (1.3 cm) EMT conduit / corner pulleys.

After determining the location of the remote pull station, the remote pull station can be mounted and the stainless-steel cable can be connected (as described above) following the appropriate directions for the version being used.

Remote Pull Station Limitations

1. Conduit and corner pulleys used with standard 1/16" (0.16 cm) stainless steel cable to connect Systems Releasing Module(s) to Pull Station:

Max. Length of Conduit: 150 feet (45.7 m)
Max. No. of Corner Pulleys: 35

2. ONLY Buckeye Shielded Cable used to connect Systems Releasing Module(s) to Pull Station:

Max. Length of BSC: 35 feet (10.7 m)
Max. No. of Bends: 6

3. Conduit and corner pulleys with standard 1/16" (0.16 cm) stainless steel cable in combination with Buckeye Shielded Cable used to connect Systems Releasing Module(s) to Pull Station:

Max. Length of Conduit: 25 feet (7.6 m)
Max. No. of Corner Pulleys: 8
Max. Length of Buckeye Shielded Cable: 35 feet (10.7 m)
Max. No. of Bends in BSC: 6

Model RPS-M: (Refer to **Figure 4-27**).

Mounting:

Option #1, Surface Mounted: Using the mounting holes in the back of the box, secure the box with mounting screws (not included) to a stud in the wall. Orientation of the box is not important, but the box should be square and level.

Option #2, Mounted in Wall (new construction): Secure the side of the box to the side of a stud using mounting screws. A deeper, metal 4 x 4 enclosure (not provided) may be needed to allow for the conduit to clear the inside of the wall and the cover plate to fit properly over the opening.

Installation:

1. Determine the best path and method cable needs to travel back to the Systems Releasing Module(s)
2. Remove one of the 1/2" conduit knock-outs and install a 1/2" conduit connector. Install the stainless-steel cable in either conduit and corner pulleys or Buckeye Shielded Cable between the remote pull station and SRM.
3. Feed the cable out of the connector and through the bushing in the back of the cover plate.
4. Place a crimp onto the cable.
5. Insert cable through the hole in the back of the pull handle and back into the crimp. Make the loop as small as place and secure the crimp with crimpers.
6. Remove cable slack.
7. Before securing cover plate to the enclosure, using two of the provided screws and nuts, fill in the two mounting holes in the cover plate that are not being used to mount the cover plate. Tightly secure these



screws. Using the remaining two screws (these may need to be unscrewed from the box), secure the cover plate to the enclosure.

8. Push the pull handle into the bushing and align the holes in the pull handle with the break rod holders.

CAUTION

Do not insert the break rod until after the operation of the RPS-M has been tested and accepted.

9. Insert the break rod through the break rod holders and the pull handle and secure with the nylon set screw provided.

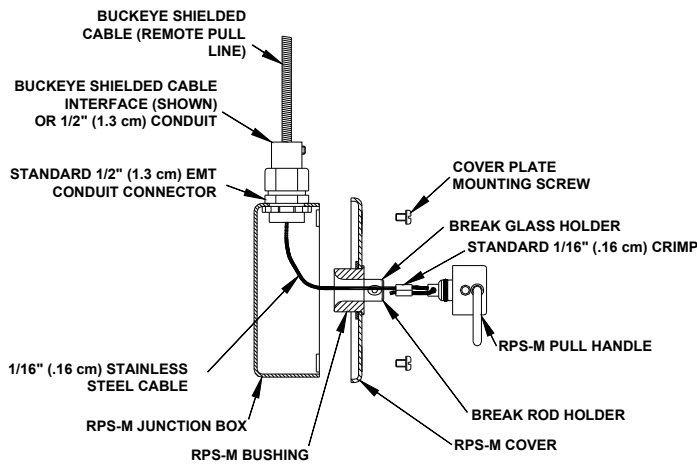

Figure 4-27.
Remote Pull Station Installation
(Shown with Buckeye Shielded Cable)

After the cable is connected, the remote pull station can be connected to the Systems Releasing Module(s) as described in the next section of this chapter.

Model RPS-M-RM: (Refer to Figure 4-28 and 4-29).

1. Locate the approximate location and lightly mark position of bushing extending from the cover plate. NOTE: The position of the bushing must not be located where a stud is placed or within 2 inches from the edge of a stud.
2. Cut an approximately 2" wide by 3" high hole in the wall with the center of the hole being the center of bushing mark. CAUTION: Check that no wiring or other hazard/obstruction is located where the hole is being placed.
3. Feed either the Buckeye Shielded Cable (recommended) through the wall and out of hole.
4. Install a Buckeye Shielded Cable Interface to the end of the shielded cable and secure. Feed cable through interface.

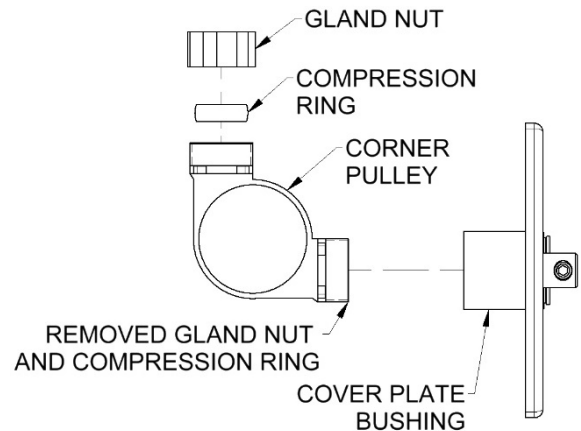

Figure 4-28.
Recessed Mount Remote Pull Station Installation
(Shown with Buckeye Shielded Cable)

5. Remove one of the gland nuts and compression ring from the supplied corner pulley and thread the corner pulley into the threaded end of the bushing, so that the corner pulley is securely attached the bushing and cover plate.
6. Insert cable through corner pulley and cover plate. Secure the Interface to the corner pulley, marking sure that the cable moves freely.
7. Insert the corner pulley into the hole in the wall and center the cover plate so that it covers the hole completely and is level. Mark the four mounting holes with a punch or other mark.
8. A) If mounting on 3/8" to 5/8" drywall the enclosed drywall anchors and screws may be used to secure the cover plate.
 - a. Move the cover plate and where the holes are marked, press tip of drywall anchor into drywall using #2 Phillips screwdriver or screw gun. Drive anchor clockwise into drywall until anchor stops flush with the outer wall surface. **TIP:** To keep anchor in precise position during installation (critical for aligning several anchors), push tip of screwdriver into drywall to mark insertion point. Repeat this until all four mounting holes are anchored. Mounting holes that are located on a stud, the drywall anchor is not needed.
 - b. Once all of the holes have been anchored feed Buckeye Shielded Cable and corner pulley back into hole and secure the cover plate with the four mounting screws provided. CAUTION: Do not use only mounting screws in drywall without anchors or two screws inserted into a stud. Failure to do so could result in the cover plate being pulled out of the wall.
- B) If mounting cover plate into a different material other than drywall then the appropriate mounting screws and anchors (not provided) must be used to securely mount the cover plate



to the wall. NOTE: The cover plate must be able to withstand a pulling force of up to 50 pounds.

9. Remove any slack in the Buckeye Shielded Cable and secure.

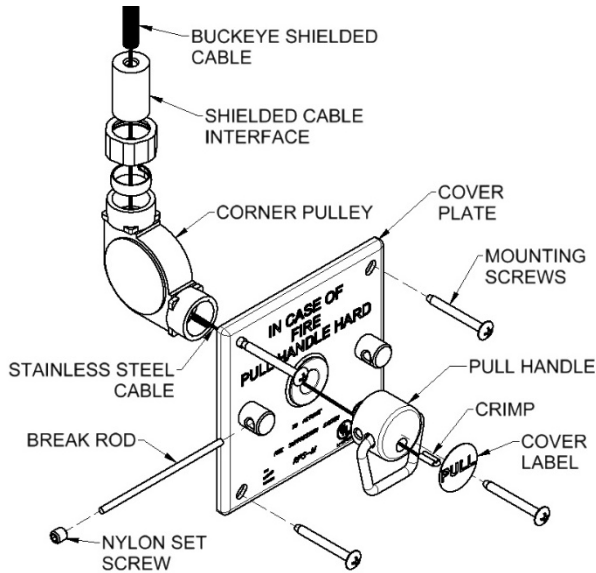

Figure 4-29.

**Recessed Mount Remote Pull Station Installation
(Shown with Buckeye Shielded Cable)**

10. Insert the exposed cable into the 3/32" hole in the back of the remote pull handle assembly and extended through the handle.
11. Attach a crimp making sure that there is no loop in the end and all extra cable is removed after crimping.
12. Pull cable and crimp back into the handle so that the crimp fits completely inside the handle.
13. Using the supplied label that reads "PULL" cover the front of the pull handle with the label.
14. Determine the best path and method (conduit and corner pulleys/Buckeye Shielded Cable/or combination) that the stainless-steel cable needs to travel back to the SRM. Remove one of the 1/2" conduit knock-outs and install a 1/2" conduit connector. Install the stainless-steel cable in either conduit and corner pulleys or Buckeye Shielded Cable between the RPS-M and SRM, as described in the technical manual.
15. From the SRM end pull any extra cable back towards the SRM so that the Pull handle at the remote pull hangs about 2 to 4 inches from the cover plate.
16. Secure the remote pull station cable to the SRM.
17. Push the pull handle into the bushing and align the holes in the pull handle with the break rods holders.



Gas Valve Installation

Restaurant systems that protect gas fueled appliances are required to shut off the gas flow upon system activation; this is accomplished by the use of a mechanical gas valve. This valve is installed in the gas supply line that feeds the cooking appliances.

Note: An arrow on the valve body shows the direction of gas flow through the valve.

After the valve is installed in the gas line, it can be connected to the Systems Releasing Module(s) as follows:

1. Using standard 1/2" (1.3 cm) EMT conduit and a corner pulley for each change in direction.
2. Using ONLY Buckeye Shielded Cable.
3. Using a combination of Buckeye Shielded Cable **and** 1/2" (1.3 cm) EMT conduit / corner pulleys.

To connect the cable to the gas valve itself, thread the cable through the top knockout in the gas valve box, loop the cable through the gas valve stem, and secure it with the crimp provided. See **Figure 4-30**. (Shown with Buckeye Shielded Cable.)

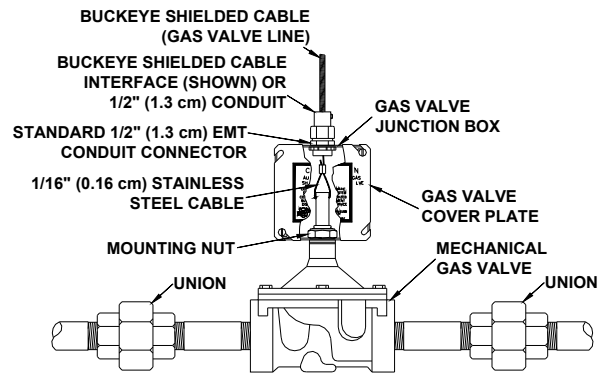

Figure 4-30.
Gas Valve Installation

Gas Valve Limitations

1. Conduit and corner pulleys used with standard 1/16" (0.16 cm) stainless steel cable to connect Systems Releasing Module(s) to Gas Valve:

Max. Length of Conduit: 150 feet (45.7 m)
Max. No. of Corner Pulleys: 35

2. ONLY Buckeye Shielded Cable used to connect Systems Releasing Module(s) to Gas Valve:

Max. Length of BSC: 35 feet (10.7 m)
Max. No. of Bends: 6

3. Conduit and corner pulleys with standard 1/16" (0.16 cm) stainless steel cable in combination with Buckeye Shielded Cable used to connect Systems Releasing Module(s) to Gas Valve

Max. Length of Conduit: 25 feet (7.6 m)
Max. No. of Corner Pulleys: 8
Max. Length of Buckeye Shielded Cable: 35 feet (10.7 m)
Max. No. of Bends in BSC: 6



Setting the Systems Releasing Module(s)

After installing the detection circuit/line, pull station line, and gas valve line, the Systems Releasing Module(s) can be connected and put into the “set position”.

Setting the Systems Releasing Module(s) – Mechanical

Model SRM2-M

Step #1: Connecting the Remote Pull Station Cable.

1. After installing the Remote Mechanical Pull Station cable, feed cable into the **Model SRM2-M** through the top left-side knockout as shown.
2. Insert the cable through one of the two holes in Locking Lever.
3. Install a cable crimp and loop the cable back through the crimp so that **NO** loop is exposed. There should be approximately 2” (5 cm) of cable left between the crimp and the Locking Lever.
4. Remove the excess cable after crimping the cable. See **Figure 4-31**.

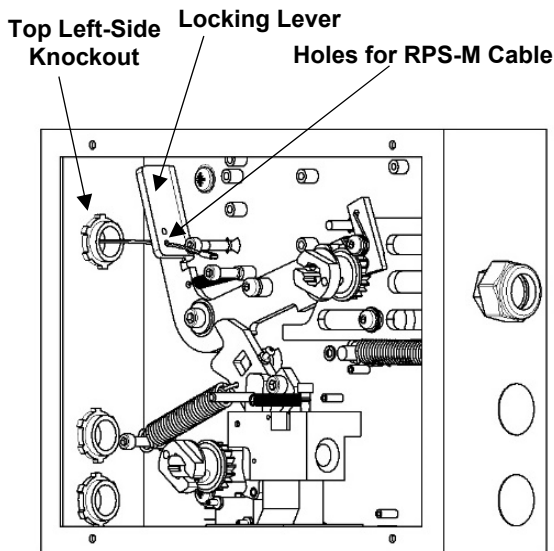

Figure 4-31.

Connecting the RPS-M Cable to the SRM2-M

CAUTION

The Locking Lever's movement **MUST NOT** be restricted or impeded by the Remote Manual Pull Station cable.

Step #2: Connecting the Fusible Link Line.

1. Feed the Fusible Link Line cable through the top right-side knockout as shown. See **Figure 4-32**.

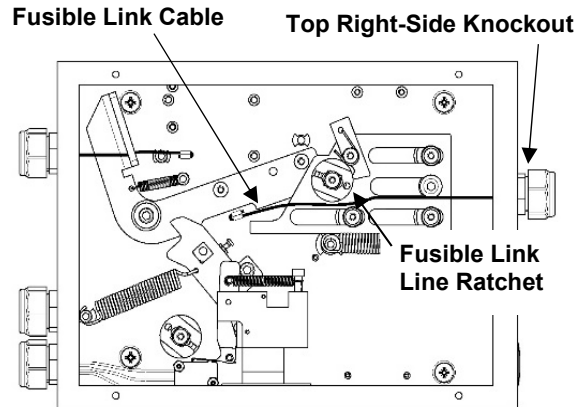

Figure 4-32.

Connecting Fusible Link Line to the SRM2-M

2. Pull all the excess slack from detection line.

Note: Fusible Link Holders and links must be installed prior to removing excess cable.

3. Pull the cable to the opposite end of **SRM2-M** and cut the cable.
4. The cable can now be connected to the fusible link ratchet wheel. This can be accomplished two different ways:

Option #1: Slide the detection cable through the hole in the fusible link ratchet wheel and crimp the end of the cable, making sure to leave enough free cable to allow for two complete wraps around the ratchet wheel when the line is tensioned. See **Figure 4-33**.

Option #2: Install a crimp at the end of the fusible link cable and insert the crimp in the center slot of the fusible link ratchet wheel. It is not necessary to use the hole provided in the fusible link ratchet wheel when this method is used. Make sure to leave enough free cable to allow for two complete wraps around the ratchet wheel when the line is tensioned. See **Figure 4-33**.

Step #3: Applying Tension to the Fusible Link Line.

1. Once the fusible link line has been attached to the Fusible Link Ratchet and all Fusible Links have been correctly positioned in the detection line, the cable is ready to be set.

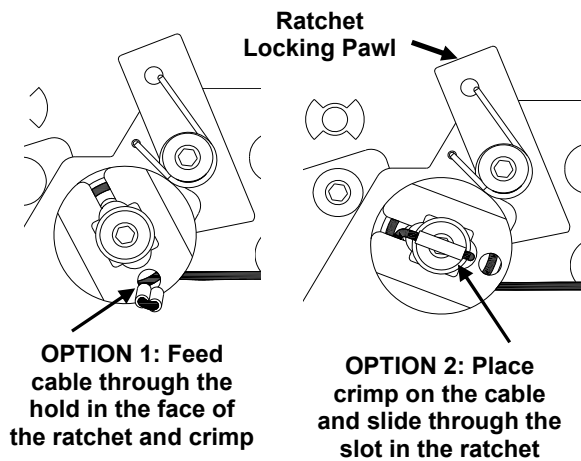

Figure 4-33.

Methods of connecting Fusible Link Line to Fusible Link Line Ratchet

- Using a ratchet (3/8" drive) rotate the Fusible Link Line Ratchet clockwise until all slack has been removed from the detection cable. See Figure 4-34.

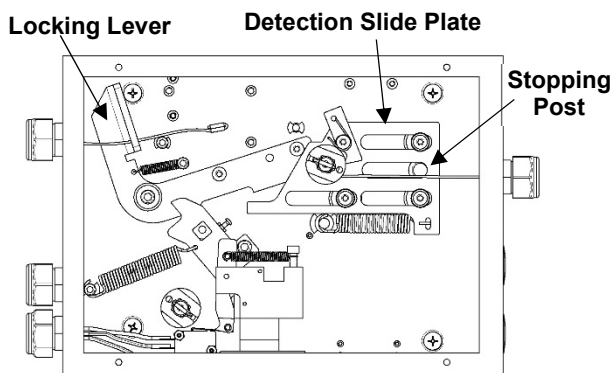

Figure 4-34.

Remove Slack from Fusible Link Line

- As you continue to rotate the Fusible Link Line Ratchet, the Detection Slide Plate will begin to move to the right, toward the Stopping Post. As the Detection Slide Plate moves to the right, the Locking Lever will fall into place. See Figure 4-35.
- Continue rotating the Fusible Line Ratchet until the Setting Screw is in the SET POSITION. See Figure 4-36.
- Once the Fusible Link Line has been properly tensioned, make sure the fusible links are still in their correct locations. If they are not, release the tension in the cable and reposition the links.

Step #4: Setting the SRM2-M.

- Using a 3/8" drive ratchet, place the ratchet into the square hole in the center of the Trigger Arm.

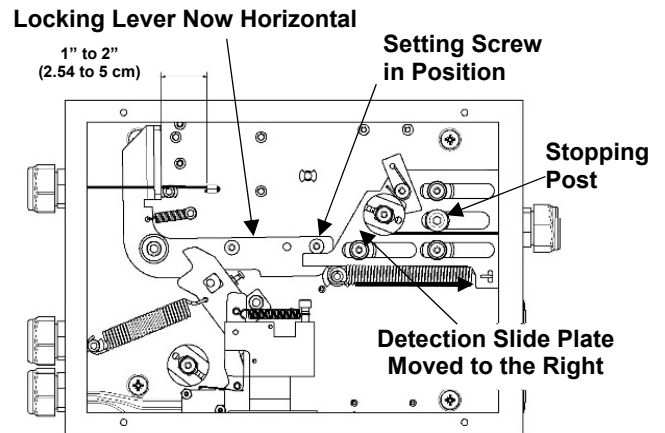

Figure 4-35.

Tensioning Fusible Link Line

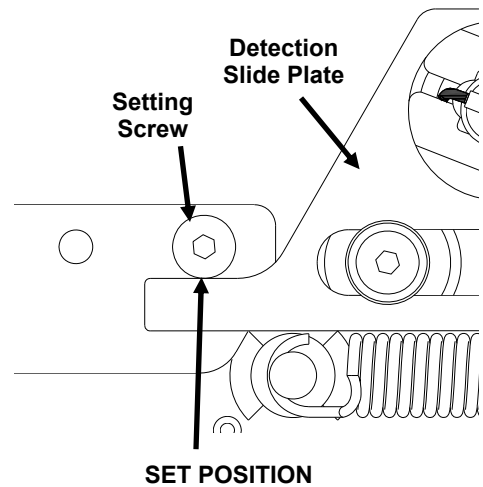

Figure 4-36.

SET Position

Center of Horizontal Area of Detection Slide Plate

- Rotate the Trigger Arm clockwise until the Locking Lever slides over the Trigger Arm and drops into the SET position. See Figure 4-37
- The Actuating Lever will move with the Trigger Arm and engage the Mechanical Gas Valve Ratchet and take the pressure off the microswitch paddles, returning them to their SET positions. See Figure 4-38.

CAUTION

If the Gas Valve Ratchet spins freely after the SRM2-M is set, the SRM2-M has NOT BEEN SET CORRECTLY. If this occurs, release the tension on the fusible link line and repeat the entire SRM2-M setting process, making sure to follow all steps carefully.

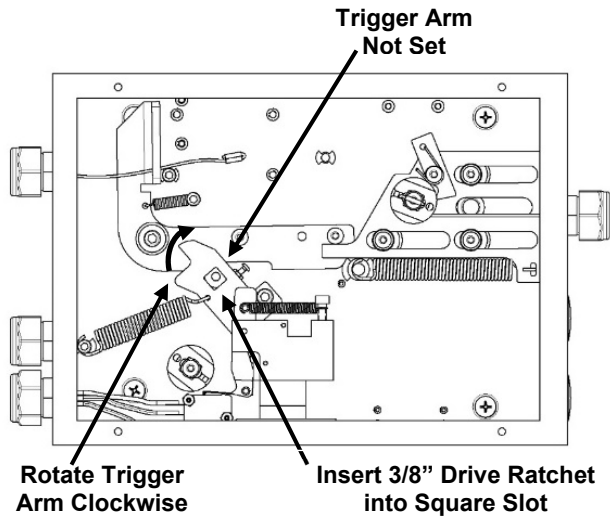

Figure 4-37.
Setting Trigger and
Actuation Arms

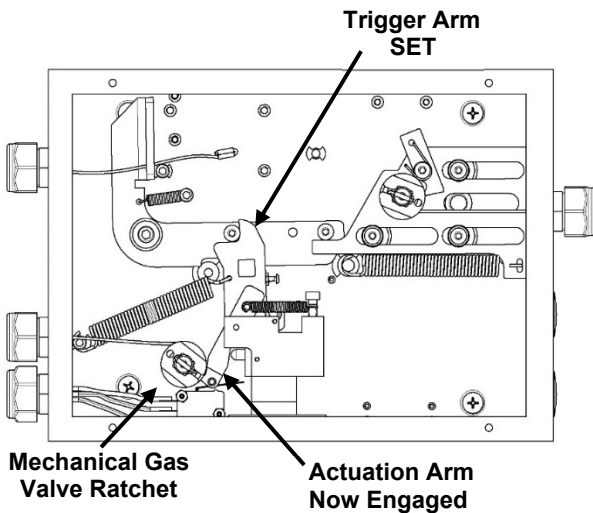

Figure 4-38.
Trigger Arm SET
Actuation Arm now Engaged

Proper Method of Releasing Fusible Link Line Tension.

1. Place the 3/8" drive ratchet into the Fusible Link Line Ratchet, turn slightly clockwise to relieve pressure on the Ratchet Locking Pawl. See **Figure 4-39**.
2. Using a screw driver, push the top of the Ratchet Locking Pawl to the left, allowing the ratchet and Fusible Link Line Ratchet to turn counter-clockwise, releasing tension in the Fusible Link Line.

WARNING
The Fusible Link Line Ratchet is under tension and could spin quickly once pawl is disengaged.

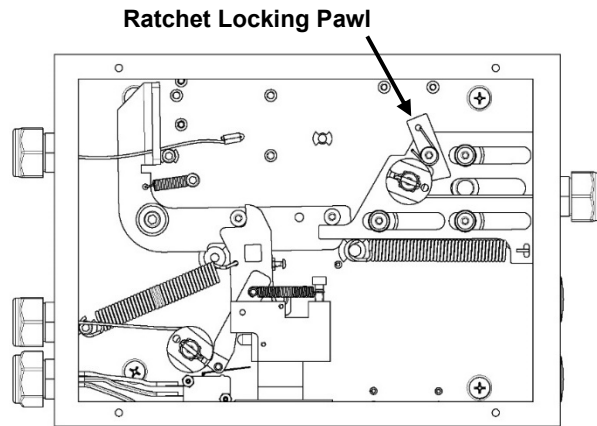

Figure 4-39.
Releasing Tension in the Fusible
Link Line

3. Slowly allow the ratchet to turn counter-clockwise and the Detection Slide Plate to move back to the left. After enough tension in the line has been released, reposition the fusible links as needed.

Step #5: Setting the Mechanical Gas Valve.

Refer to **Setting the Mechanical Gas Valve** section of this chapter. After setting, check gas valve to ensure that it is in its full open position.



Model SRM

Step #1: Connecting the Remote Pull Station Cable.

1. After installing the Remote Mechanical Pull Station cable, feed cable into the Systems Releasing Module through the top right knockout as shown.
2. Feed cable through the hole in Manual Release Lever and remove the excess cable.
3. Install a cable crimp and loop the cable back through the crimp so that **NO** loop is exposed. There should be approximately 1" (2.5 cm) of cable left between the crimp and the Manual Release Lever. See **Figure 4-40**.

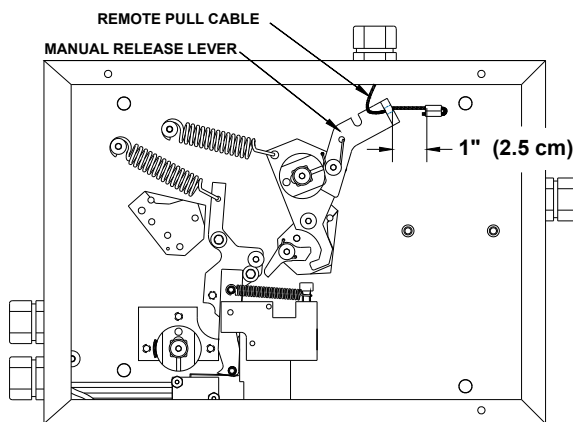

Figure 4-40.
Mechanical Pull Station Cable Connection

CAUTION

The Manual Release Lever's movement **MUST NOT** be restricted or impeded by the Remote Mechanical Pull Station cable. After installing cable, check that the Manual Release Lever engages properly with the Detection Ratchet. Failure to do so could result in the detection line not engaging correctly.

Step #2: Connecting the Fusible Link Line.

1. After installing the fusible link line cable, feed cable into the Systems Releasing Module through the top right-side knockout as shown. See **Figure 4-42**.
2. Pull all the excess slack from detection line.
Note: If using Fusible Link Holders, all holders and links must be installed prior to removing excess cable.
3. Pull the cable to the opposite end of Systems Releasing Module and cut the cable.

4. The cable can now be connected to the fusible link ratchet wheel. This can be accomplished two different ways:

Option #1: Slide the detection cable through the hole in the fusible link ratchet wheel and crimp the end of the cable, making sure to leave enough free cable to allow for two complete wraps around the ratchet wheel when the line is tensioned. See **Figure 4-41**.

Option #2: Install a crimp at the end of the fusible link cable and insert the crimp in the center slot of the fusible link ratchet wheel. It is not necessary to use the hole provided in the fusible link ratchet wheel when this method is used. Make sure to leave enough free cable to allow for two complete wraps around the ratchet wheel when the line is tensioned. See **Figure 4-41**.

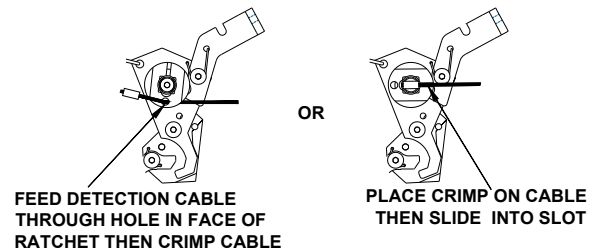

Figure 4-41.
Two Methods of Connecting Fusible Link Line to Fusible Link Ratchet

5. Turn the Fusible Link Ratchet clockwise by hand to take up any remaining slack in the fusible link line.

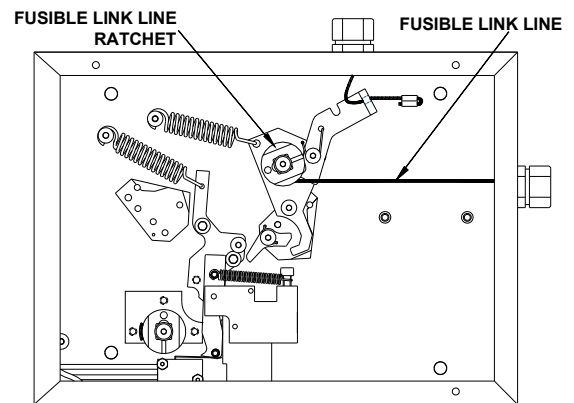

Figure 4-42
Connecting Fusible Link Line to Systems Releasing Module

Note: The detection cable must be positioned so that it stays in the channel of the Fusible Link Ratchet.



Step #3: Applying Tension to the Fusible Link Line.

1. Once the fusible link line has been attached to the Fusible Link Ratchet and all Fusible Links have been correctly positioned in the detection line, the cable is ready to be set.
2. Make sure the Catch is in the “set” position. See **Figure 4-43**.

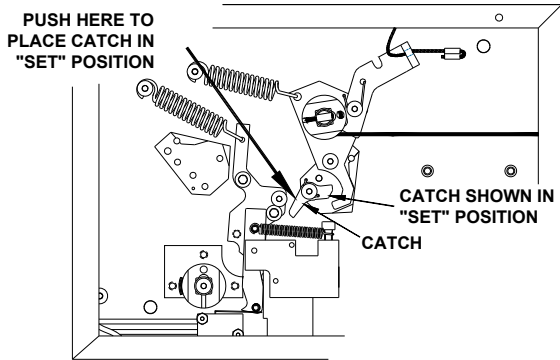

Figure 4-43
Catch in “SET” Position

3. Using a 3/8” (1.0 cm) ratchet with an extension, rotate the Fusible Link Ratchet clockwise until all slack has been removed from the cable and the Detection Arm begins to move. See **Figure 4-44**.

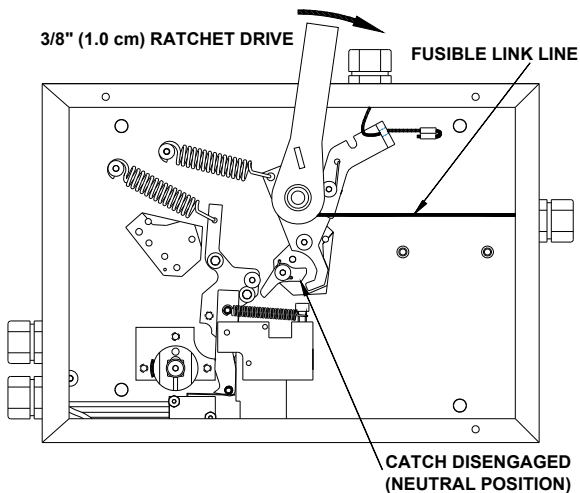

Figure 4-44.
Applying Tension to the Fusible Link Line

4. Continue to turn clockwise until all the slack has been removed and the Detection Arm just touches the STOP located on the Detection Arm Block, fully engaging the Catch. See **Figure 4-45**.

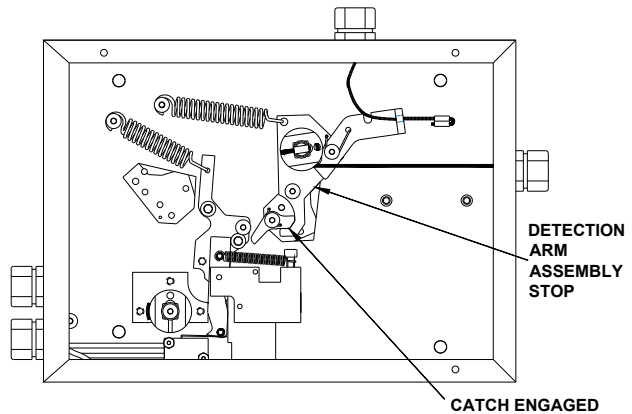

Figure 4-45.
Fusible Link Line in Set Position

5. Firmly push the Detection Arm to the left with your finger to remove any additional slack from the detection line; this will remove any additional slack from the fusible link line (see **Figure 4-46**). **Caution: DO NOT** push on the Manual Release Lever.
6. If the Detection Arm moves away from its STOP position, rotate the Fusible Link Ratchet until the Detection Arm JUST touches its STOP position again. **Repeat this procedure** until the **Detection Arm cannot be moved from the STOP position when pushed with your finger**.

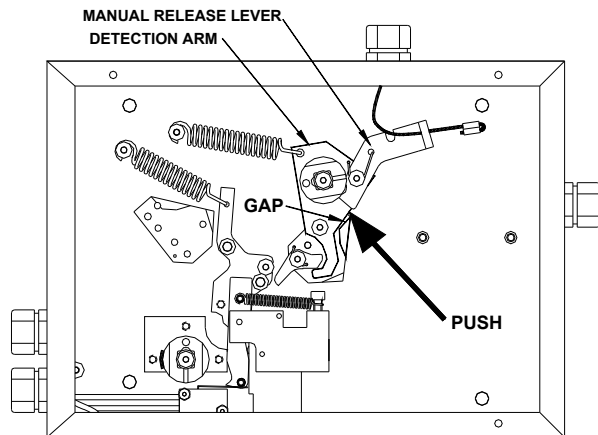

Figure 4-46.
Removing Additional Slack

CAUTION
Do not over tighten the detection line once the Detector Arm Assembly has come in contact with the stop and has fully engaged the Catch.



Step #4: Before Setting the Systems Releasing Module.

1. Make sure the Detection Arm is against its STOP. Refer to **Figure 4-45**.
2. Check the Catch to make sure it is moving freely and properly engaged with the Detection Arm. Refer to **Figure 4-45**.
3. Make sure that all fusible links and Fusible Link Holders are in their proper position. If fusible links or Fusible Link Holders are not positioned correctly, release the tension from the fusible link line, reposition the fusible links, and repeat this procedure.
4. Make sure that the crimp on the end of the Remote Pull Station line is about 1" below the Manual Release Lever. Refer to **Figure 4-40**.

Step #5: Setting the Systems Releasing Module.

1. Locate the 3/16" (0.5 cm) hex head socket on the Detection Trigger See **Figure 4-47**.

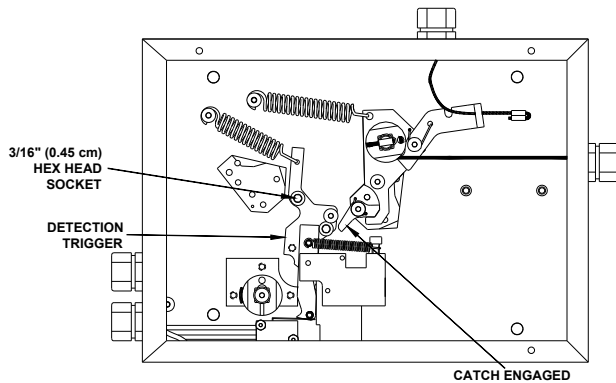

Figure 4-47.
Locate 3/16" (0.5 cm) Hex Head Socket

2. Using a ratchet with a 3/16" (0.5 cm) hex-bit socket (Allen type), rotate the Detection Trigger to the right until the Catch snaps into place, locking the Trigger in the SET position. See **Figure 4-48 & Figure 4-49**.

Step #6: Setting the Mechanical Gas Valve.

Refer to **Setting the Mechanical Gas Valve** section of this chapter. After setting, check gas valve to ensure that it is in its full open position.

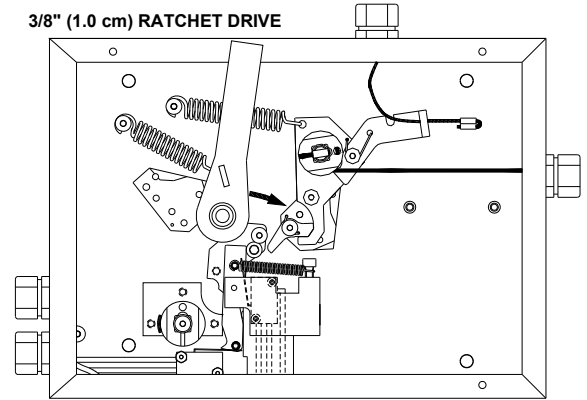

Figure 4-48.
Setting Detection Trigger

CAUTION

If the Gas Valve Ratchet spins freely after the SRM is set, the SRM has **NOT BEEN SET CORRECTLY**. If this occurs, release the tension on the fusible link line and repeat the entire SRM setting process, making sure to follow all steps carefully.

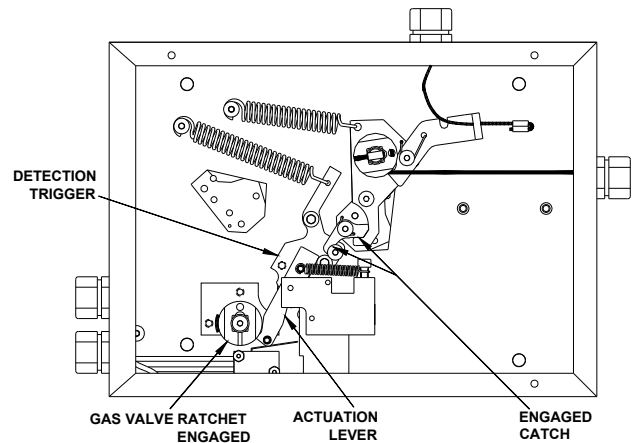

Figure 4-49.
Systems Releasing Module,
Shown in SET Position



Model SRM-D

The Buckeye Fire Equipment Systems Releasing Module can also be supplied with a secondary, independent detection line. To have this option available it is necessary to order the **Model SRM-D**.

Step #1: Connecting the Remote Pull Station Cable.

1. After installing the Remote Mechanical Pull Station cable, feed cable into the Systems Releasing Module through the top right knockout as shown.
2. Feed cable through the hole in Manual Release Lever and remove the excess cable.
3. Install a cable crimp and loop the cable back through the crimp so that **NO** loop is exposed. There should be approximately 1" (2.5 cm) of cable left between the crimp and the Manual Release Lever. See **Figure 4-50**

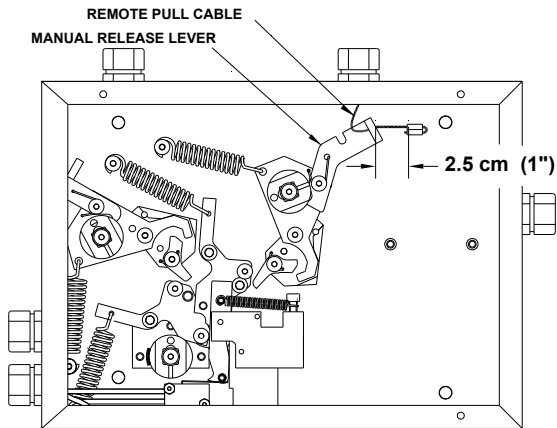

Figure 4-50.
Mechanical Pull Station Cable Connection to the SRM-D

CAUTION

The Manual Release Lever's movement **MUST NOT** be restricted or impeded by the Remote Mechanical Pull Station cable. After installing cable, check that the Manual Release Lever engages properly with the Detection Ratchet. Failure to do so could result in the detection line not engaging correctly.

Step #2: Setting the SRM-D

Following Steps 2 through 5 given for the **Model SRM**, to set the primary detection line of the SRM-D. See **Figure 4-51**.

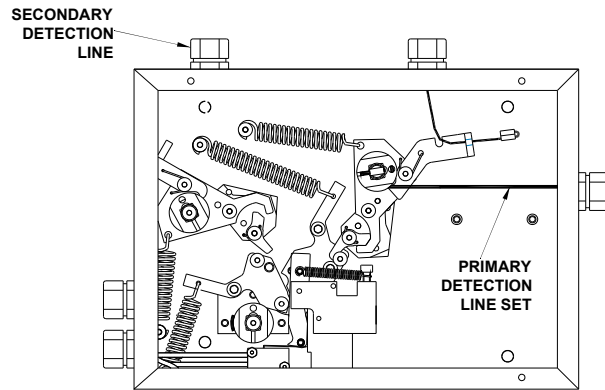

Figure 4-51.
Primary Fusible Link Line SET
Systems Releasing Module - Dual

Step #3: Connecting and Setting the Optional Secondary Detection Line (For Model SRM-D, Systems Releasing Module, Dual Detection).

Follow the same procedures given in Steps 2 through 5 that were used to set the primary detection line (see **Setting the Systems Releasing Module(s) – Mechanical, Model SRM**), with the following exceptions:

1. The secondary detection line will enter the enclosure from the top left knock out as shown in **Figure 4-50**.
2. Place the Keeper Safety Pin into the Primary Detection Arm Assembly to prevent the accidental release of the primary Detection Cable. See **Figure 4-52**.

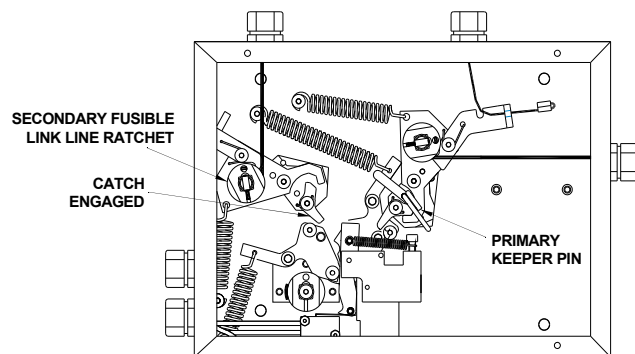

Figure 4-52.
Securing Primary Fusible Link Line

3. Using a 3/16" hex wrench or ratchet with a 3/16" hex-bit socket, rotate (in a clockwise motion) the Secondary Detection Trigger upwards, until the Catch snaps into place, locking the Trigger in the SET position. Insert second Keeper Pin if desired. See **Figure 4-53**.

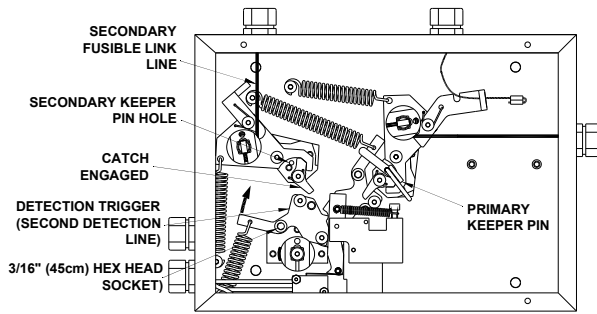

Figure 4-53.
Setting Secondary Detection Trigger

NOTE: When using a **Model SRM-D** both Keeper Pins must be removed before putting the control head into service. All other steps are the same for the **Model SRM** and **Model SRM-D**.

Step #4: Setting the Mechanical Gas Valve (SRM-D Only)

NOTE: When using a **Model SRM-D** the Secondary Detection Line must be SET before trying to set the Mechanical Gas Valve Line.

1. After installing the gas valve cable as described previously, feed cable into the Systems Releasing Module through the top left-side knockout as shown.
2. With the excess slack removed from the cable, cut it so that about 3" (7.6 cm) of cable extends past the Gas Valve Ratchet. See **Figure 4-54**.
3. The cable can now be attached to the Gas Valve Ratchet in the same manner that the fusible link line was connected to the fusible link line ratchet. See **Figure 4-41**.

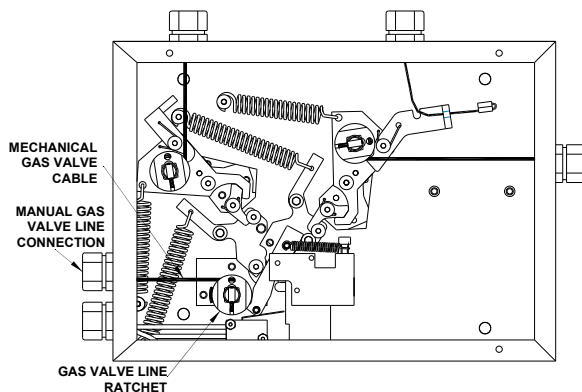
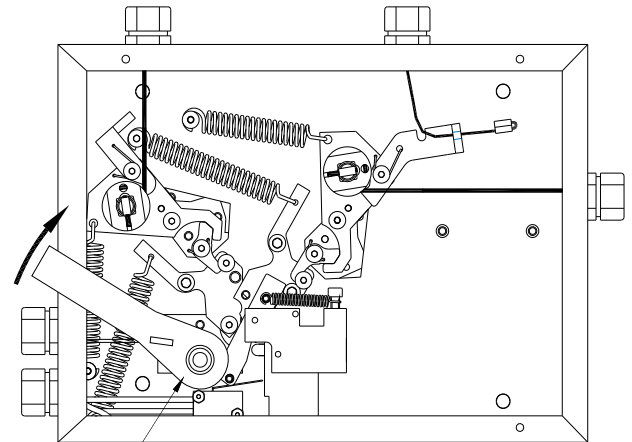

Figure 4-54.
SRM-D Gas Valve Ratchet and Cable

4. Turn the Mechanical Gas Valve Ratchet by hand clockwise to take up any remaining slack in the Mechanical Gas Valve Line. The Mechanical Gas Valve Line must be positioned so that it stays in the channel (smaller diameter) of the Mechanical Gas Valve Ratchet.
5. Using a ratchet (3/8" (1.0 cm) drive) or wrench [3/4" (1.9 cm)], rotate the Gas Valve Ratchet clockwise until all slack has been removed from the cable and the Mechanical Gas Valve stem begins to move. See **Figure 4-55**.



3/8" (1.0 cm) RATCHET DRIVE

Figure 4-55.
Applying Tension to the SRM-D Mechanical Gas Valve Cable

6. Continue to turn spool clockwise until all slack has been removed and the Mechanical Gas Valve stem is fully extended, and the Gas Valve is in its full open position. Remove ratchet or wrench and check the Gas Valve to ensure that it is in its full open position. See **Figure 4-56**.

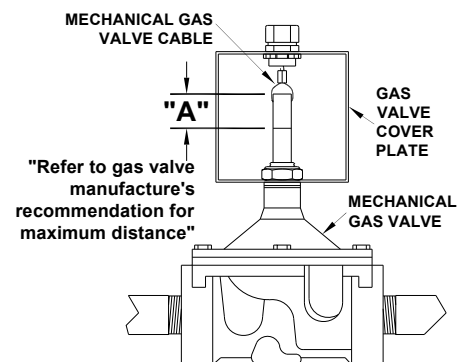

Figure 4-56.
Mechanical Gas Valve in "Set" Position



Setting the Systems Releasing Module(s) – Electrical

Model SRM2-E-24 and SRM2-E-120

Step #1: Connecting the Remote Pull Station Cable. (Refer to Figure 4-57.)

1. After installing the Remote Mechanical Pull Station cable, feed cable into the **Model SRM2-M** through the top left-side knockout as shown.
2. Insert the cable through one of the two holes in Locking Lever.
3. Install a cable crimp and loop the cable back through the crimp so that **NO** loop is exposed. There should be approximately 2" (5 cm) of cable left between the crimp and the Locking Lever.
4. Remove the excess cable after crimping the cable.

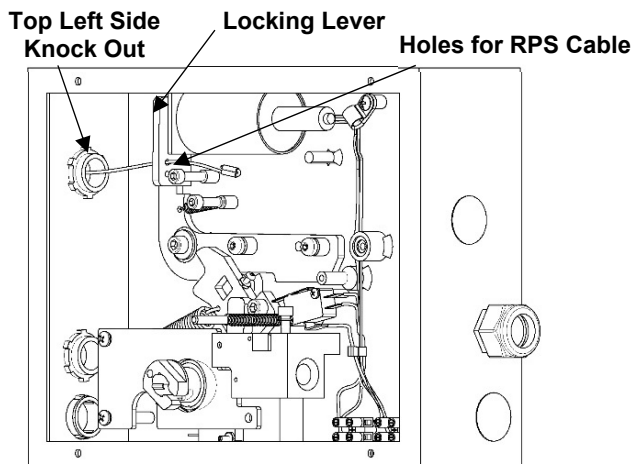

Figure 4-57.

Connecting the RPS-M Cable to the SRM2-E

CAUTION

The Locking Lever's movement MUST NOT be restricted or impeded by the Remote Manual Pull Station cable.

Step #2: Install Electrical Thermal Detectors

Electrical thermal detectors are always used in conjunction with the **Model SRM2-E-24/120** Systems Releasing Module. After mounting the cylinder and System Releasing Module, the thermal detector(s) can be installed. See **Chapter 3** for detector placement guidelines. Follow the instructions included with the detector for proper detector mounting procedures.

Step #3: Install the Solenoid Monitor

After installing the thermal detectors and the Systems Releasing Module, the **Solenoid Monitor** can be installed.

The **SM-24** is used with the **SRM-E-24** and the **SM-120** is used with the **SRM-E-120**.

The **Solenoid Monitor** is an end-of-line device that supervises the detection/actuation circuit. When the detection/actuation circuit is properly installed and energized, the light on the Solenoid Monitor will be illuminated indicating that the circuit is functioning properly.

Solenoid Monitor Mounting

1. The solenoid monitor should be mounted in a location where it can be easily observed and readily accessible
2. The panel mounts directly to a three-gang electrical conduit switch box (provided by others), that is at least 3-1/4" (8.3 cm) deep. See **Figure 4-58**.

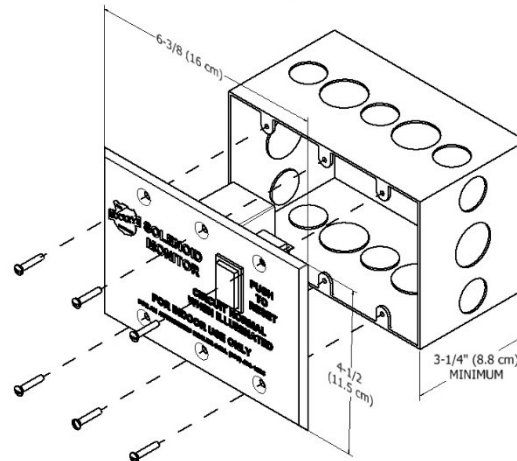

Figure 4-58

Mounting of the Solenoid Monitor

Step #4: Connecting the Detection/Actuation Circuit

The **Model SRM-E-24** Electrical Systems Releasing Module requires a 24 VDC power supply with a 2A rating. The detection/actuation circuit shall be supervised by the **Model SM-24** Solenoid Monitor (see Solenoid Monitor Installation). See **Figure 4-59**.

The **Model SRM-E-120** Electrical Systems Releasing Module requires a 1A, 120 VAC power supply. The detection/actuation circuit shall be supervised by the **Model SM-120** Solenoid Monitor (see Solenoid Monitor Installation). See **Figure 4-59**.



WARNING

Before working on any electrical wiring, make certain main power has been disconnected. Failure to disconnect main power could cause personal injury, death and/or damage to equipment, if contact is made with energized wires. All electrical wiring and connections to be made in accordance with the authority having jurisdiction and all applicable national and local codes.

All wiring for the detection/actuation circuit shall be at least 14 gauge or as required by applicable codes. All wiring and conduit installations shall meet all applicable national, state, and local code.

Once the Systems Releasing Module, thermal detectors, power supply, and Solenoid Monitor have been installed the detection/actuation circuit can be wired as follows (see **Figure 4-58**):

1. Feed the detection circuit wiring through the bottom right-side knockout and connect each lead to the terminal block as shown.
2. The neutral or negative wire from the power supply and the neutral or negative wire from the first thermal detector are inserted into the top two open terminal ports (one wire in each port) of the terminal block located in the lower right corner of the **SRM2-E**. A ground wire shall be attached to the bottom port of the connection terminal. The other wire (line/positive) from the thermal detector will be

connected to the line/positive port of the power supply. See **Figure 4-58** and **Figure 4-59**.

3. The remaining thermal detectors are then wired in series with the last detector being wired to the solenoid monitor.

NOTE:

Supervision shall be provided in accordance with NFPA-17A if electrical detection and/or actuation is provided.

Alarms and indicators along with a supervised backup power source shall be provided in accordance with NFPA 72, The National Fire Alarm Code.

Electrical wiring and equipment shall be installed in accordance with NFPA 70, National Electric Code or the requirements of the authority having jurisdiction.

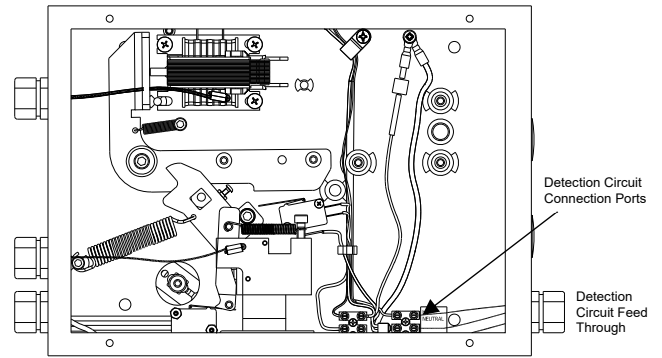

Figure 60.

Detector Connection Points (SRM2-E-120 Shown)

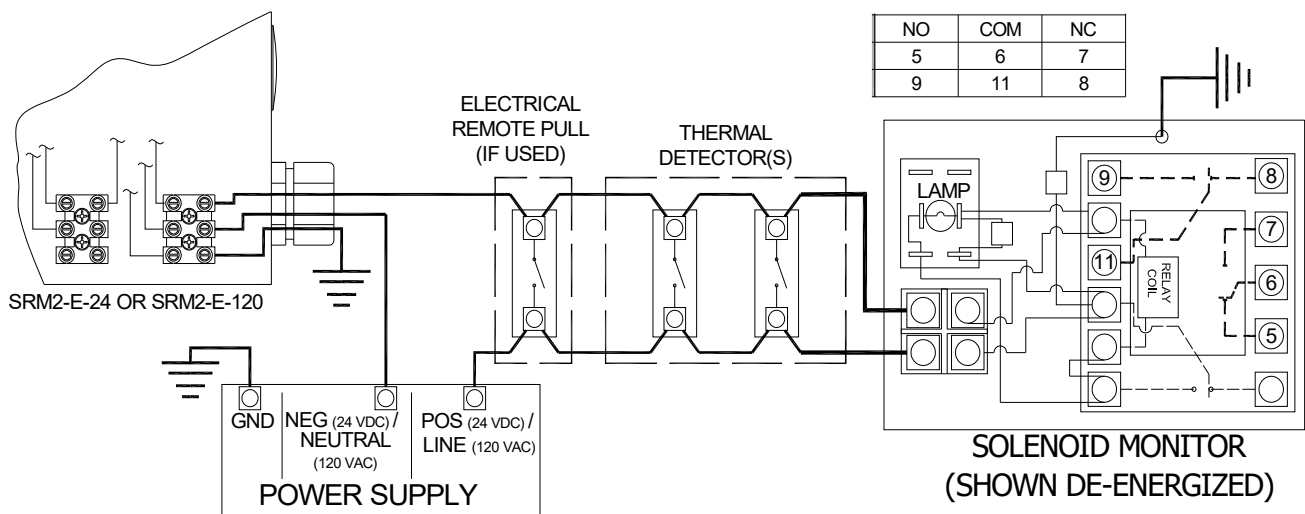

Figure 4-59

Model SRM-E-24/120 Systems Releasing Module Wiring Schematic



If using an approved releasing panel, refer to the panel's installation instruction for connecting the SRM2-E to the releasing circuit of the panel.

Step #5: Setting the SRM2-E-24/120.

1. Using a 3/8" drive ratchet, place the ratchet into the square hole in the center of the Trigger Arm.
2. Rotate the Trigger Arm clockwise until the Locking Lever slides over the Trigger Arm and drops into the SET position. See **Figure 4-61**

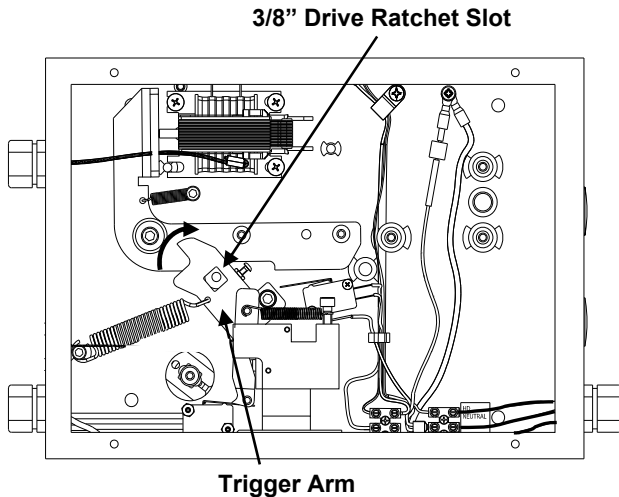

Figure 4-61.
Setting the Model SRM2-E-24/120,
Shown Before Setting

3. The Actuating Lever will move with the Trigger Arm and engage the Mechanical Gas Valve Ratchet and take the pressure off the microswitch paddles, returning them to their SET positions. See **Figure 4-62**.

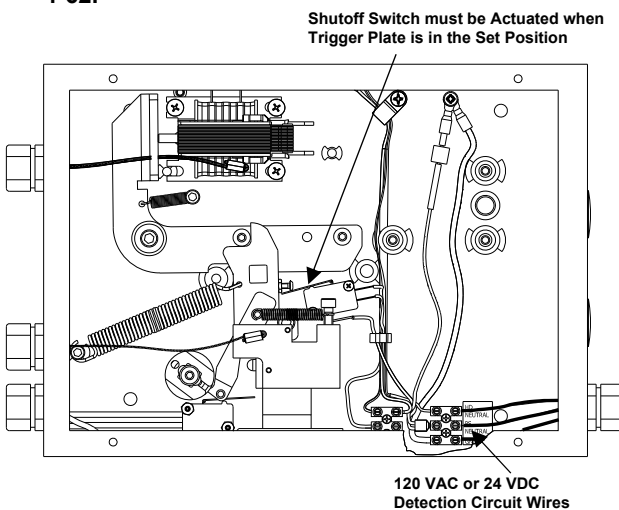

Figure 4-62
Model SRM-E-24/120 Shown SET
Solenoid Shutoff Switch Engaged

Note: When the Trigger Plate is in the SET position, the Solenoid Shutoff Switch must be actuated (the paddle held down) for the solenoid to operate.

CAUTION

If the Gas Valve Ratchet spins freely after the SRM2-M is set, the SRM2-M has NOT BEEN SET CORRECTLY. If this occurs, release the tension on the fusible link line and repeat the entire SRM2-M setting process, making sure to follow all steps carefully.

Step #6: Setting the Mechanical Gas Valve.

Refer to **Setting the Mechanical Gas Valve** section of this chapter. After setting, check gas valve to ensure that it is in its full open position.

Step #7: Energizing the Circuit.

WARNING

Before working on any electrical wiring, make certain main power has been disconnected. Failure to disconnect main power could cause personal injury, death and/or damage to equipment, if contact is made with energized wires. All electrical wiring and connections to be made in accordance with the authority having jurisdiction and all applicable national and local codes.

Once the solenoid monitor has been installed and correctly wired, the detection/actuation circuit can be connected to the appropriate power supply and energized.

CAUTION

Before energizing the circuit, the first time, the agent cylinder(s) should **NOT** be connected to the Systems Releasing Module. The agent cylinder should only be connected to the system releasing module after the system has been properly tested and ready to be put into service.

To energize the detection /actuation circuit, push the reset button. The light in push-button switch should illuminate and stay illuminated once the switch is released, indicating the circuit has been properly installed and ready for service. If the light does not illuminate, the circuit must be checked. See **Figure 4-63** and **Figure 4-64**.

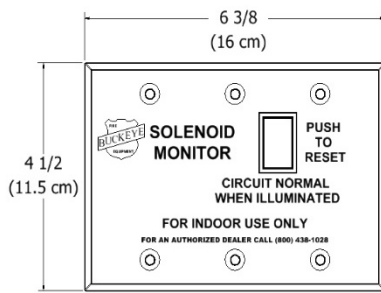

Figure 4-63.
Solenoid Monitor

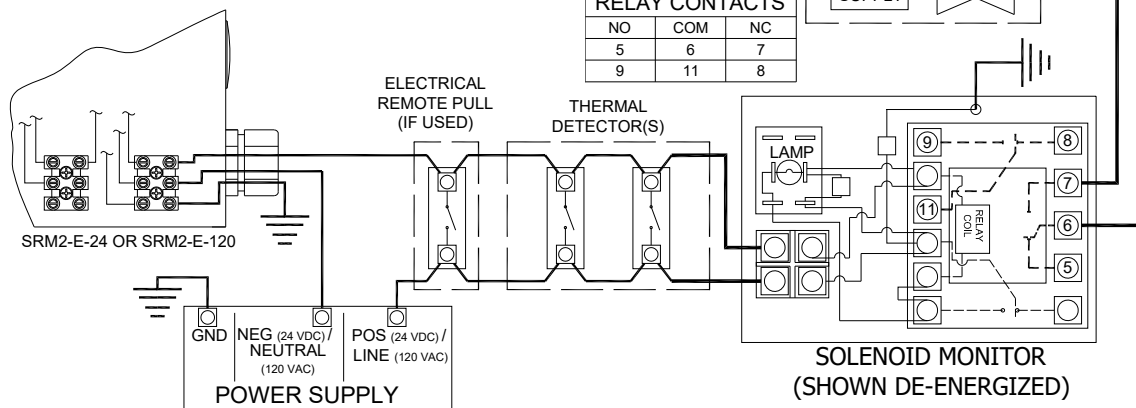

Figure 4-64
Electrical SRM2-E- Wiring Schematic

If the solenoid monitor does not light or stay illuminated:

1. Check that all wire connections are tight and made correctly.
2. Check that the power source is working properly (refer to instructions provided by the power source manufacture).
3. Check that all devices are functioning properly (refer to instructions provided by manufacture).
4. Call technical support.

Solenoid Monitor When Used as a Reset Relay

The **Model SM-24** and **Model SM-120** can be used as a reset relay when required. A reset relay is required when an electronical gas shutoff valve is used.

The **Model SM-24** can be used as a reset relay when a 24 VDC gas shutoff valve is installed.

The **Model SM-120** can be used as a reset relay when a 120 VAC gas shutoff valve is installed.



Setting the Mechanical Gas Valve.

1. After installing the gas valve cable as described previously, feed cable into the Systems Releasing Module through the left-side knockout as shown. See **Figure 4-65**.

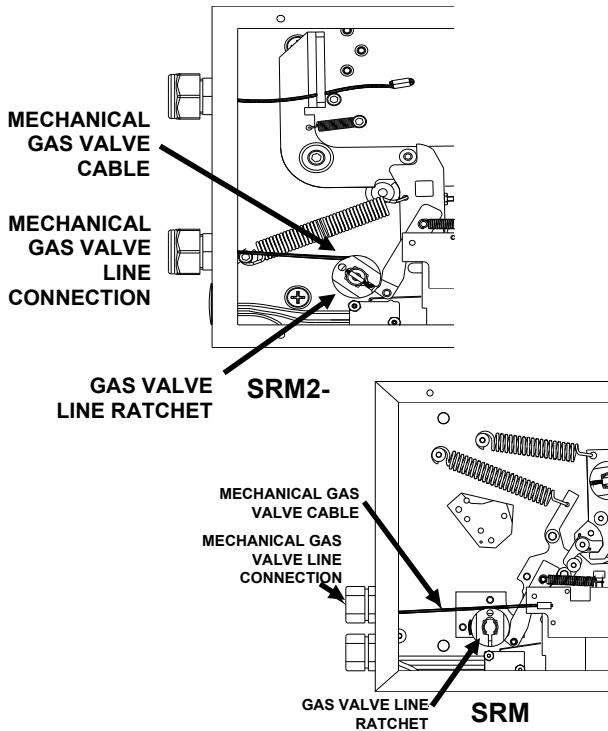

Figure 4-65.

Mechanical Gas Valve Connection and Ratchet

2. With the excess slack removed from the cable, cut it so that about 3" (7.6 cm) of cable extends past the Gas Valve Ratchet.
3. The cable can now be attached to the Gas Valve Ratchet in the same manner that the fusible link line was connected to the fusible link line ratchet. See **Figure 4-33**.
4. Turn the Mechanical Gas Valve Ratchet by hand clockwise to take up any remaining slack in the Mechanical Gas Valve Line. The Mechanical Gas Valve Line must be positioned so that it stays in the channel (smaller diameter) of the Mechanical Gas Valve Ratchet and does not interfere with the movement of the Actuation Lever.

CAUTION

If the Gas Line Cable interferes with the movement of the Actuation Lever the Systems Releasing Module(s) will fail to actuate.

5. Using a ratchet (3/8" (1.0 cm) drive) or wrench [3/4" (1.9 cm)], rotate the Gas Valve Ratchet clockwise until all slack has been removed from the cable and the Mechanical Gas Valve stem begins to move. See **Figure 4-66**.

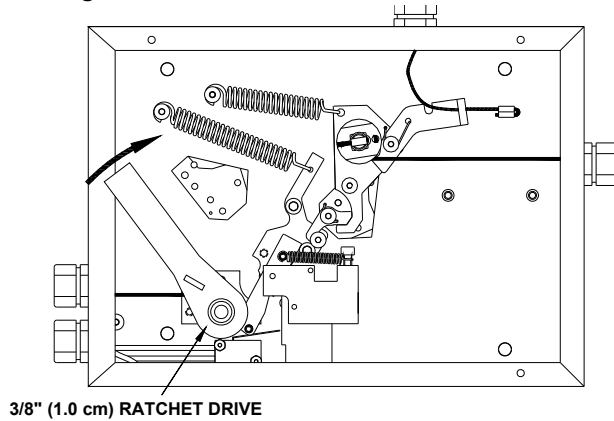

Figure 4-66.

Applying Tension to the Mechanical Gas Valve Cable (SRM Shown)

6. Continue to turn spool clockwise until all slack has been removed and the Mechanical Gas Valve stem is fully extended, and the Gas Valve is in its full open position. Remove ratchet or wrench and check the Gas Valve to ensure that it is in its full open position. See **Figure 4-67**.

CAUTION

Do not over tighten the Mechanical Gas Valve line once the Mechanical Gas Valve stem has been extended to its full open position.

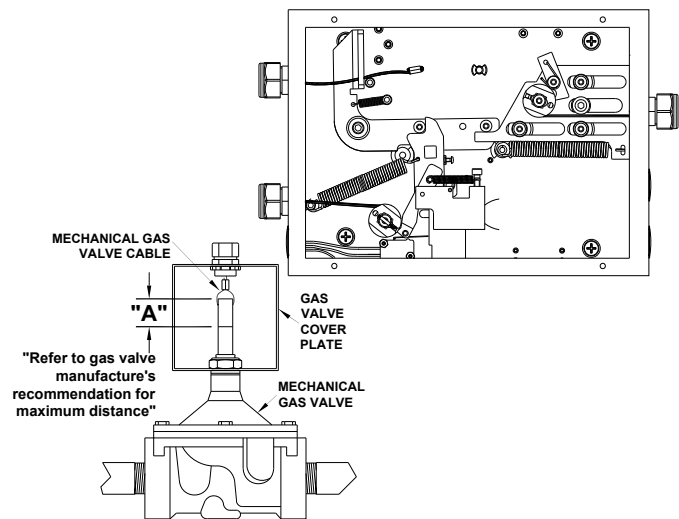

Figure 4-67.

Mechanical Gas Valve in "Set" Position (SRM2-M Shown above)



Installing the Nitrogen Actuation Cartridge.

If this is a new installation, refer to the next section, System Check Out after Installation, before installing the Nitrogen Actuation Cartridge.

1. Before installing the Nitrogen Cartridge, it is necessary to make sure that the Actuating Pin is moving freely. Insert the **Model BFR-PRT**, Actuation Pin Resetting Tool into the threaded hole of the Manifold Mounting Block where the Nitrogen Cartridge is installed. See **Figure 4-68**.
2. After screwing the resetting tool fully in, the Actuating Pin is now in the set position and an Actuation Cartridge can now be installed.

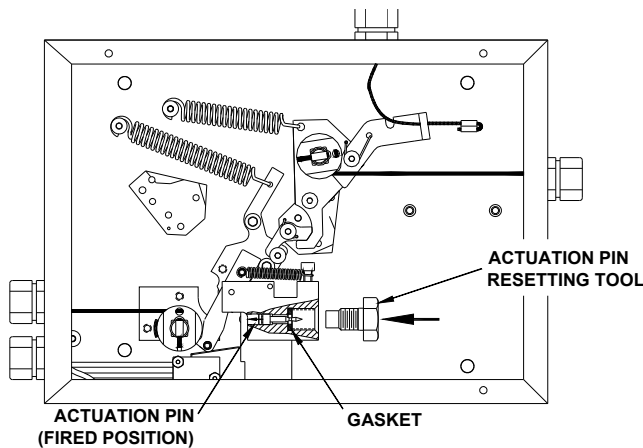

Figure 4-68.
Setting Actuation Pin (SRM Shown)

CAUTION

Before installing the Nitrogen Actuation Cartridge, the installer shall inspect the sealing cap for punctures or other damage and verify that the cartridge weighs more than the stated minimum gross weight stamped on the cartridge. If any evidence of damage, puncture or if the cartridge weighs less than minimum gross weight, empty cartridge then discard and replace.

3. **ONLY** a Buckeye Nitrogen Actuation Cartridge may be used in the Systems Releasing Module(s). Carefully hand-tighten the Nitrogen Cartridge completely into the threaded hole of the Manifold Mounting Block. This should take approximately ten (10) full turns of the cartridge. See **Figure 4-69**.

WARNING

After installing the nitrogen cartridge, the system is in the SET position and is ready to actuate.

4. In the grey area provided, write the “date of installation” on the Nitrogen Cartridge. **The cartridge must be replaced within one (1) year of installation.** See **Figure 4-70**.

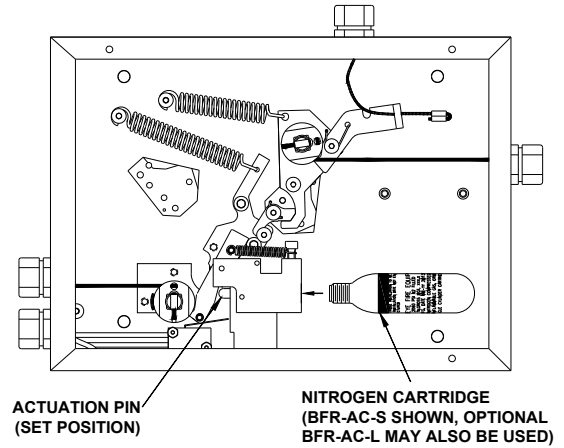

Figure 4-69
Installing Nitrogen Cartridge (SRM Shown)

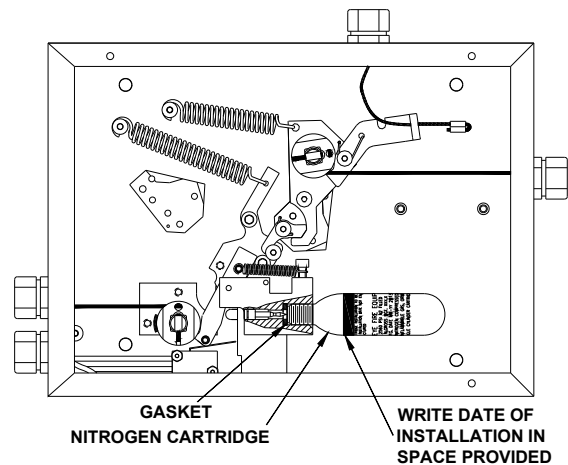
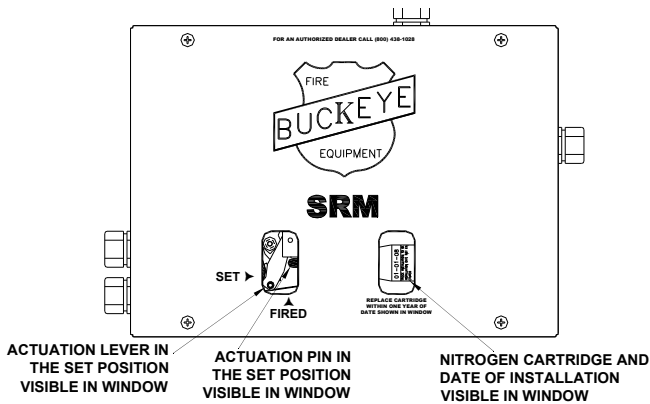

Figure 4-70.
Dating Nitrogen Cartridge (SRM Shown)



Installing the Systems Releasing Module Cover Plate

1. Check that the Keeper Safety Pin, if used, has been removed and all cables have been properly set.
2. Place the cover back on the Systems Releasing Module enclosure, making sure that the labels are properly oriented and the four (4) mounting holes line up.
3. Secure the cover to the enclosure using the four (4) 10-24 X 3/8" (1.0 cm) self-tapping screws provided.



**Figure 4-71.
Installing Systems Releasing Module(s) Cover
(SRM Shown)**



System Checkout after Installation:

Mechanical (Models SRM, SRM-D and SRM2-M).

1. Before putting the system into service all components shall be checked for proper operation, including, the actuation of a nitrogen cartridge.
2. Disconnect the Systems Releasing Module(s) from the cylinder valve or if the Systems Releasing Module is mounted remotely, remove all **Model BFR-CAP(s)**, Valve Cap Assembly from each of the cylinder valve(s).

CAUTION

Failure to disconnect the Systems Releasing Module(s) or Valve Cap(s) from the cylinder valve(s) prior to the test firing of the nitrogen cartridge will cause system discharge.

3. Install a Nitrogen Actuation Cartridge if it is not already installed.
4. Activate the Systems Releasing Module by releasing tension from the end of the fusible link line.
5. Make certain that the Systems Releasing Module actuates causing the Nitrogen Actuation Cartridge to puncture, the mechanical gas valve(s) to close, and all auxiliary devices connected to the micro-switches to operate or stop.

CAUTION

If any of these events do not occur, determine the cause of the problem and repeat this step. **DO NOT** put the system into service until the cause of the problem is determined, the appropriate steps are taken to solve the problem, and the system is successfully re-tested.

6. Remove the used Nitrogen Actuation Cartridge and discard immediately.
7. Repair the fusible link line and inspect all fusible links and fusible link holders assuring they are in the correct location.

Note: If testing the **Model SRM-D**, before testing the remote pull station, the secondary detection line **MUST** be tested. Once both fusible link lines of been successfully tested, the Systems Releasing Module can be reset, and the remote pull station tested.

8. Reset the Systems Releasing Module and then activate the system by using the remote pull station.

9. Make certain that the Systems Releasing Module actuates, the mechanical gas valve(s) closes, and all auxiliary devices connected to the micro-switches operate or stop.

CAUTION

If any of these events do not occur, determine the cause of the problem and repeat this step. **DO NOT** put the system into service until the cause of the problem is determined, the appropriate steps are taken to solve the problem, and the system is successfully re-tested.

10. Reset the Systems Releasing Module.
11. Reconnect and secure the Systems Releasing Module(s) or Valve Cap Assembly(s) to the appropriate cylinder valve(s).

CAUTION

The Interface Gasket or O-ring must be properly installed between the SRM and top of the cylinder valve assembly. Failure to do so may result in system failure.

After assuring that the Systems Releasing Module(s) is functioning properly, has been reset and either directly or remotely connected to the cylinder valve assembly(s), the system can be put into operation.



System Checkout after Installation:

Electrical (Models SRM2-E-24 and SRM2-E-120).

1. Before putting the system into service all components shall be checked for proper operation, including, the actuation of a nitrogen cartridge.
2. Disconnect the Systems Releasing Module(s) from the cylinder valve or if the Systems Releasing Module is mounted remotely, remove all **Model BFR-CAP(s)**, Valve Cap Assembly from each of the cylinder valve(s).

CAUTION

Failure to disconnect the Systems Releasing Module(s) or Valve Cap(s) from the cylinder valve(s) prior to the test firing of the nitrogen cartridge will cause system discharge.

3. Install a Nitrogen Actuation Cartridge if it is not already installed.
4. Activate the Systems Releasing Module by activating a heat detector in accordance with the manufacturer's instructions.

Note: Per NFPA 72, two or more thermal detectors per circuit shall be tested. Within a five-year period, all heat shall be tested

5. Make certain that the Systems Releasing Module actuates causing the Nitrogen Actuation Cartridge to puncture, the mechanical gas valve(s) to close, the Solenoid Monitor indicator light will stop illuminating, and all auxiliary devices connected to the micro-switches to operate or stop.

CAUTION

If any of these events do not occur, determine the cause of the problem and repeat this step. DO NOT put the system into service until the cause of the problem is determined, the appropriate steps are taken to solve the problem, and the system is successfully re-tested.

6. Remove the used Nitrogen Actuation Cartridge and discard immediately.
7. Inspect the thermal detectors for any signs of damage. If any damage is noted the detector must be replaced.

CAUTION

The thermal detectors must be allowed to re-set before re-setting the Systems Releasing Module. To be sure the thermal detectors have reset, momentarily depress the Solenoid Shutoff Switch (**DO NOT HOLD SWITCH CLOSED**) in the Systems Releasing Module, if the solenoid fires the thermal detector(s) has not reset. Wait until depressing the switch does not cause the solenoid to fire before re-setting the Systems Releasing Module.

CAUTION

If any of these events do not occur, determine the cause of the problem and repeat this step. DO NOT put the system into service until the cause of the problem is determined, the appropriate steps are taken to solve the problem, and the system is successfully re-tested.

8. Reset the Systems Releasing Module and Solenoid Monitor and then activate the system by using the remote pull station.
9. Make certain that the Systems Releasing Module actuates causing the Nitrogen Actuation Cartridge to puncture, the mechanical gas valve(s) to close, the Solenoid Monitor indicator light will stop illuminating, and all auxiliary devices connected to the micro-switches to operate or stop.
10. Re-set the remote pull station.
11. Reset the Systems Releasing Module and Solenoid Monitor.
12. Reconnect the Systems Releasing Module(s) or Valve Cap Assembly(s) to the appropriate cylinder valve(s) and secure each with the four provided screws.

CAUTION

The Interface Gasket or O-ring must be properly installed between the SRM and top of the cylinder valve assembly. Failure to do so may result in system failure.

After assuring that the Systems Releasing Module(s) is functioning properly, has been reset and either directly or remotely connected to the cylinder valve assembly(s), the system can be put into operation.



Putting the System into Operation:

After assuring that the Systems Releasing Module(s) is functioning properly, has been reset and either directly or remotely connected to the cylinder valve assembly(s), the system can be put into operation.

1. Check that all other components of the system are in place (i.e. fusible links, nozzle caps, etc.) and in the proper operational condition (i.e. pressure gauge, gas valve, etc.).
2. Install a new Nitrogen Actuation Cartridge.

CAUTION

Before installing the Nitrogen Actuation Cartridge, the installer shall inspect the sealing cap for punctures or other damage and verify that the cartridge weighs more than the stated minimum gross weight stamped on the cartridge. If any evidence of damage, puncture or if the cartridge weighs less than minimum gross weight, empty cartridge then discard and replace.

3. Write the current date on the grey band of a new Nitrogen Actuation Cartridge so that it can be seen in the viewing window of the Systems Releasing Module.
4. Re-install the Systems Releasing Module cover. Verify that the date on the cartridge is visible in the viewing window.
5. The Owner's Manual should be given to the End User or their designated representative.

The Buckeye Fire Equipment *Kitchen Mister* Fire Suppression System is now fully functional. The system's operation and what is required of the End User should be reviewed with the End User or their designated representative. Refer to Owner Manual and Maintenance Section of this manual for additional details.



This Page Intentionally Blank.



Chapter 5

System Inspection and Maintenance

Maintenance Overview

This chapter will detail the basic procedures for proper maintenance of the Buckeye Fire Equipment *Kitchen Mister* Fire Suppression System.

Maintenance of the *Kitchen Mister* System must be in compliance with the parameters set forth in this manual and be performed by a factory trained, Authorized Buckeye Fire Equipment Dealer. Buckeye Fire Equipment is not responsible for systems installed or maintained by personnel that are not factory trained and Authorized.

Owners Inspection - Monthly

Monthly inspections shall be performed as per NFPA-17A and are required by Buckeye Fire Equipment.

On a monthly basis the owner of the *Kitchen Mister* Fire Suppression System must perform the following “quick check” to verify the following:

1. The extinguishing system is in its proper location.
2. The manual actuators are unobstructed.
3. The tamper indicators and seals are intact.
4. The maintenance tag or certificate is up to date and in place.
5. No obvious physical damage or condition exists that might prevent operation.
6. The pressure gauge is in the operable range.
7. The nozzle blow off caps are intact and undamaged.
8. The hood, duct, and cooking appliances have not been replaced, modified, or relocated.

If any deficiencies are found the owner is to contact an Authorized Buckeye Fire Equipment Distributor immediately.

Note: A record of monthly inspections is to be kept by the owner of the system that includes the date of inspection, the person performing the inspection, and any corrective action required.

Semi-Annual Maintenance

Semi-annual maintenance of the *Kitchen Mister* System is required by NFPA-17A and Buckeye Fire Equipment and must be performed by a factory trained, Authorized Buckeye Fire Equipment Dealer. Semi-annual maintenance shall include the following:

1. Check that the hazard area has not changed.
2. Check the cylinder pressure gauge, making sure it is in the operable range.
3. Check all nozzle orifices to assure that they are unobstructed and that all nozzle caps are in place.

CAUTION

Nozzles must be completely unobstructed and show no signs of internal blockage. If nozzle(s) show any signs of internal damage or blockage, remove nozzle from service and replace with a new nozzle.

4. If any BFR-UBC stainless steel metal caps are used, they must be removed, cleaned and checked to assure that they slide easily on and off the nozzle body. If the cap does not slide easily off the nozzle tip, the O-ring and cap must be replaced.
5. Remove the face plate from the control head.
6. **Remove the actuation nitrogen cartridge from the Systems Releasing Module(s).**

CAUTION

Buckeye Fire Equipment recommends the testing of all Systems Releasing Module functions during semi-annual maintenance as required by NFPA 17A.

7. Check entire system for mechanical damage.
8. Inspect fusible link detection line for grease build-up or mechanical damage. Replace corner pulleys, or conduit if necessary.

If thermal heat detectors are being used inspect the detectors for any signs of damage. Carefully wipe clean any grease that may have accumulated on the detectors. If any damage is noted the detector should be replaced.
9. Activate the Systems Releasing Module(s) by releasing tension from the end of the fusible link line by cutting or melting the last link. If using an Electric Systems Releasing Module(s), activate each heat detector. Make certain that the Systems Releasing Module(s) fires, the gas valve closes, and all auxiliary devices connected to the micro-switch operate or stop.
10. Replace all fusible link detectors.



11. Reset the Systems Releasing Module(s) and then activate the system by using the remote pull station. Make certain that the Systems Releasing Module(s) fires, the gas valve closes, and all auxiliary devices connected to the micro-switch operate or stop.

After the Systems Releasing Module(s) has been tested and is functioning properly, the system can be put back into service.

12. If a Keeper Pin was used, remove it from the Systems Releasing Module(s). Refer to the Keeper Pin section of the appendix.
13. Before installing the Nitrogen Actuation Cartridge, it is necessary to make sure that the Actuation Pin is moving freely. Insert the Actuation Pin Resetting Tool into the threaded hole of the Manifold Mounting Block where the Nitrogen Cartridge is installed and then remove the **BFR-PRT**.

CAUTION

Before installing the Nitrogen Actuation Cartridge, the installer shall inspect the sealing cap for punctures or other damage and verify that the cartridge weighs more than the stated minimum gross weight stamped on the cartridge. If any evidence of damage, puncture or if the cartridge weighs less than minimum gross weight, empty cartridge then discard and replace.

14. Install the Nitrogen Actuation Cartridge by completely screwing the cartridge into the manifold block.
15. Re-install the Systems Releasing Module(s) cover. Verify that the date on the cartridge is visible in the viewing window.

Annual Maintenance

Annual maintenance of the *Kitchen Mister* System is required by NFPA-17A and Buckeye Fire Equipment and must be performed by a factory trained, Authorized Buckeye Fire Equipment Dealer. Annual maintenance shall include the following:

1. Check and inspect the system in accordance with steps 1 – 7 of semi-annual maintenance instructions.

CAUTION

Failure to disconnect the Systems Releasing Module or Valve Cap(s) from the cylinder valve(s) prior to the test firing of the nitrogen cartridge will cause system discharge (see below).

2. Disconnect the Systems Releasing Module(s) from the cylinder valve by removing the four screws securing the SRM to the top of the valve and separate. DO NOT lose or damage the Interface Gasket or O-ring, because it will be required to reconnect the SRM. If the SRM is mounted remotely, remove all **Model BFR-CAP(s)**, Valve Cap Assembly

from each of the cylinder valve(s) by unscrewing the four mounting screws and remove them from the cylinder valve(s).

3. Reinstall the Nitrogen Activation Cartridge.
4. If the Systems Releasing Module(s) is a mechanical type (**Models SRM, SRM-D or SRM2-M**) check the satisfactory operation of the fusible link system, by cutting the terminal link or the "S" Hook attached to the terminal link.

If the Systems Releasing Module(s) is an electrically operated type (**Models SRM2-E-24 and SRM2-E120**) then each thermal heat detector needs to be tested (as instructed by manufacturer of the heat detector).

Note: Per NFPA 72, two or more detectors per circuit shall be tested. Within a five-year period all heat detectors must be tested.

Either one of these methods of actuation will cause the following to occur:

- i. **Models SRM or SRM-D:** The Systems Releasing Module(s) will operate, causing the detection arm assembly to move back to the left, disengaging the trigger, and allowing the actuation lever to operate. The actuation pin will puncture the nitrogen cartridge and allow the nitrogen gas to discharge through the bottom of the SRM(s) or BFR-CAP(s).

Model SRM2-M: The SRM2-M will operate, causing the detection slide plate to slide to the right, rotating the locking lever up, disengaging the trigger plate, and allowing the actuation lever to operate. The actuation pin will puncture the nitrogen cartridge and allow the nitrogen gas to discharge through the bottom of the SRM2-M or BFR-CAP(s).

Models SRM2-E-24 or SRM2-E-120: The SRM2-E solenoid will operate, causing the Locking Lever to rotate up, disengaging the Trigger Plate, and allowing the Actuation Lever to operate. The Actuation Pin will puncture the nitrogen cartridge and allow the nitrogen gas to discharge through the bottom of the SRM2-E or BFR-CAP(s).

- ii. The pressurization indicator of each Test Valve Assembly (when used) will be fully extended and there are no leaks in the copper tubing.
- iii. The gas valve will close, stopping gas flow to any gas fueled appliances.
- iv. All auxiliary devices connected to the miniature electrical switch(s) provided in the Systems Releasing Module(s) will have operated.



- v. If applicable, the Solenoid Monitor indicator light will stop illuminating, indicating that the circuit is in trouble.

CAUTION

If any of these events do not occur when the terminal link is cut, determine the cause of the problem and repeat this step. DO NOT put the system into service until the cause of the problem is determined, the appropriate steps are taken to solve the problem, and the system is successfully re-tested.

5. Remove the used nitrogen cartridge and discard immediately.
6. Replace all fusible link detectors.
7. After testing the fusible link line, repair the terminal link and re-set the control head as described in Chapter 4.

If electric detection is being used the heat detectors must be allowed to reset and the Solenoid Monitor must be reset by pushing the Reset Button before trying to reset the Systems Releasing Module(s).

8. Once the Systems Releasing Module(s) is reset, the mechanical pull station must be checked. To do so, pull the handle on the remote pull station and make sure that the following occurs:
 - i. **Models SRM and SRM-D:** The Systems Releasing Module(s) will operate, causing the detection arm assembly to move back to the left, disengaging the trigger, and allowing the actuation lever to operate.
Model SRM2-M: The SRM2-M will operate, causing the locking lever to rotate up, disengaging the trigger plate, and allowing the actuation lever to operate.
Model SRM2-E24 or SRM2-E-120: The SRM2-E will operate, causing the locking lever to rotate up, disengaging the trigger plate, and allowing the actuation lever to operate.
 - ii. The gas valve will close, stopping gas flow to any gas fueled appliances.
 - iii. All auxiliary devices connected to the miniature electrical switch(s) provided in the Systems Releasing Module(s) will have operated.
 - iv. If applicable, the Solenoid Monitor indicator light will stop illuminating, indicating that the circuit is in trouble

CAUTION

If any of these events do not occur when the manual pull station is operated, determine the cause of the problem and repeat this step. DO NOT put the system into service until the cause of the problem is determined, the appropriate steps are taken to solve the problem, and the system is successfully re-tested.

9. Disconnect the discharge piping from the cylinder valve. Using air or nitrogen, blow out the discharge piping and make sure all the nozzle caps have blown off. If any nozzle cap(s) fails to blow off during test, carefully examine piping system and nozzle(s) to determine cause and take appropriate corrective action. Repeat test to assure both piping system and nozzles are unobstructed.
10. Reconnect the discharge piping to the cylinder valve and check that all nozzle caps are installed properly.
11. Reconnect the Systems Releasing Module(s) or Valve Cap Assembly(s) to the appropriate cylinder valve(s) and secure each with the four provided screws.

Refer to page 4-1 or 4-2 of this manual, Mounting Systems Releasing Module(s) Directly to the Cylinder Valve or Wall Mounting of Systems Releasing Module(s).
12. If used, remove the keeper pin from the Systems Releasing Module(s).
13. Before installing the Nitrogen Cartridge, it is necessary to make sure that the Actuating Pin is moving freely. Insert the Actuation Pin Resetting Tool into the threaded hole of the Manifold Mounting Block where the Nitrogen Cartridge is installed.

CAUTION

Before installing the Nitrogen Actuation Cartridge, the installer shall inspect the sealing cap for punctures or other damage and verify that the cartridge weighs more than the stated minimum gross weight stamped on the cartridge. If any evidence of damage, puncture or if the cartridge weighs less than minimum gross weight, empty cartridge then discard and replace.

14. Install a new Nitrogen Actuation Cartridge by completely screwing the cartridge into the manifold block. Refer to Chapter 4, Step #8, Installing the Nitrogen Activation Cartridge (page 4-20 of this manual).
15. Write the current date on the grey band of a new Nitrogen Actuation Cartridge so that it can be seen in the viewing window of the SRM.



16. Re-install the Systems Releasing Module(s) cover.
Verify that the date on the cartridge is visible in the viewing window.

12 Year Maintenance

In addition to the required annual maintenance, all agent cylinders must be removed from the system, discharged, and hydrostatically tested as per the requirements of NFPA-17A. The cylinder should then be recharged in accordance with this manual and returned to service.

Note: New extinguishing agent must be used when performing this procedure.



Chapter 6 System Recharge

Overview

This chapter will detail the basic procedure for recharging the system after it has been activated.

Recharging the *Kitchen Mister* System must be in compliance with the parameters set forth in this manual and be performed by a factory trained, Authorized Buckeye Fire Equipment Dealer. Buckeye Fire Equipment is not responsible for systems installed or maintained by personnel that are not factory trained and authorized.

VALVE REBUILDING COMPONENTS

Valve Rebuilding Kit

The **Model BFR-VRK** Valve Rebuilding Kit includes all the necessary components to properly rebuild the system valve. After the *Kitchen Mister* System has been actuated, the valve must be re-built to assure proper operation. See **Figure 6-1**.

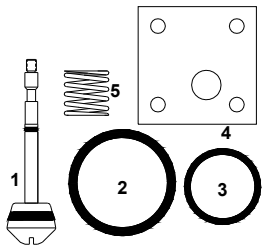

Valve Rebuilding Components			
Item	Description	Qty.	Part No.
1	Valve Stem Assembly	1	PVA10021
2	O-Ring, Cylinder Vlv.	1	POS10016
3	O-Ring, Piston	2	POS10015
4	Gasket - VLV / SRM	1	POS10123
5	Piston Spring	1	PSP10011

Figure 6-1.
Model BFR-VRK,
Valve Rebuilding Kit

CAUTION

Failure to rebuild the valve after system actuation may result in pressure leakage and system failure. The valve **MUST** be rebuilt after every system actuation.

Valve Rebuild Tool

The **Model BFR-VRT** Valve Rebuilding Tool is required to properly rebuild the cylinder valve. It is used to hold the piston in place while the valve stem is unscrewed. If it is not used, valve damage may occur. See **Figure 6-2**.

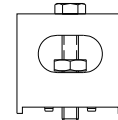

Figure 6-2.
Model BFR-VRT,
Valve Rebuilding Tool

System Recharge

1. After a system discharge it is essential that all the extinguishing agent be cleaned up in a timely manner to avoid possible corrosion of cooking appliances, hood, and duct. Clean up discharged agent with warm soapy water then rinse area with warm, clean water to assure all agent is removed. It is recommended that gloves be worn during this procedure.

WARNING

Before cleaning the hazard area, make sure that it is de-energized and has cooled down to room temperature.

2. Before beginning recharging procedure, determine the cause of the discharge and take appropriate corrective action.
3. Inspect the entire system for mechanical damage and take appropriate corrective action if any is found. If the cylinder has sustained any mechanical damage it must be hydrostatically tested before returning it to service.

WARNING

Some residue pressure from the actuation gas may be released from the piston chamber of the cylinder valve.

4. Disconnect the Systems Releasing Module(s) or Valve Cap Assembly from the cylinder(s).
5. Disconnect the Discharge Adapter from the cylinder valve by unscrewing the two (2) 1/4(0.6 cm)-20 hex



head screws holding the Discharge Adapter Plate to the valve. Slide the Discharge Adapter out of the discharge port of the cylinder.

- Remove the cylinder from its mounting bracket by loosening the mounting strap and lifting off the cylinder.

WARNING

Cylinder assembly is heavy and should be handled with care. To prevent damage to discharge port and piston chamber, an anti-recoil and shipping plate must be installed on the cylinder valve whenever the cylinder is being transported.

- Before proceeding, the entire piping system must be flushed with hot water for a minimum of 10 minutes. Leaving the nozzles in place will facilitate the flushing process. Remove the Discharge Adapter from the piping system and attach the appropriate hose adapter needed to flush the piping.
- To assure that no water or chemical is left in the piping, the piping must be blown out with compressed air or nitrogen, until the pipe is dry.
- Make note of each nozzles' position, then remove all system nozzles. Remove the internal strainer from each, wash all parts in hot soapy water, and rinse.
- Re-install the internal strainer and retaining ring in each nozzle and inspect the orifice for any damage or obstruction. Replace the nozzle cap on each nozzle.
- Once all nozzles and piping are dry and clean, the nozzles can be re-installed on the system.
- Remove the valve and siphon tube slowly to allow any residual pressure remaining in the cylinder to be released.
- Remove the siphon tube from the valve assembly.
- Remove the valve stem and wash the valve with warm soapy water rinsing afterwards to remove any residue chemical from the valve.

CAUTION

Make certain to install the nozzles in their correct position after cleaning. Refer to the Design Section of this manual (**Chapter 3**) to verify proper nozzle placement and aiming.

- Rebuild the valve with the **Model BFR-VRK** Valve Rebuilding Kit as per the instructions provided with the kit.
- Screw the siphon tube back into the rebuilt valve assembly, using Teflon tape to assure a good seal.
- Discard any agent that may still be in the cylinder.

- Fill the tank with the required amount of Kitchen Mister agent, see chart below.

Recharge Agent Quantities Required

<u>Cylinder</u>	<u>Recharge Required</u>
BFR-5	1 x BFR-5R
BFR-10	1 x BFR-10R or 2 x BFR-5R
BFR-15	1 x BFR-5R and 1 x BFR-10R
BFR-20	2 x BFR-10R's

- Reinstall the valve and siphon tube into the filled cylinder. The valve must be screwed all the way into the cylinder so that it sits flush with the cylinder neck. The valve must be hand tight when screwed completely into the cylinder neck.
- Install the recharge adaptor and pressurize the cylinder with dry nitrogen to a maximum pressure of 195 psi. (1344 KPa) +/- 4% at 70°F (21°C).

CAUTION

When using a high-pressure gas cylinder, a pressure regulator shall be used. The system pressure gauge shall not be used to determine the charge pressure. A properly calibrated external gauge shall be used.

- Wait 15 minutes to assure the pressure in the tank is still 195 psi (1344 KPa). If pressure has dropped below 195, open pressure fill valve and bring back up to 195 psi (1344 KPa).
- Pull the detent pin out, to release the valve stem, allowing the valve to close.
- The yellow pointer in the cylinder gauge should be in the green section of the gauge directly over the line marked 195 psi.
- Replace **ALL** fusible links.
- Reinstall the cylinder and Systems Releasing Module(s) (or valve cap assembly) and reconnect the system piping.

WARNING

Cylinder assembly is heavy and should be handled with care. To prevent damage to discharge port and piston chamber, an anti-recoil and shipping plate must be installed on the cylinder valve whenever the cylinder is being transported.

- Reset the system controls as per the instructions in the Installation Chapter (**Chapter 4**) of this manual.



SAFETY DATA SHEET LIQUID FIRE SUPPRESSION AGENT

SECTION I. Chemical Product and Company Identification

Identification of the preparation

Product Name: “Liquid Fire Suppression Agent”
Chemical Name: N/A - This is a mixture/preparation.
CAS No.: N/A - This is a mixture/preparation.
Chemical Formula: N/A - This is a mixture/preparation.
EINECS Number: N/A - This is a mixture/preparation.

Use of the preparation

The intended or recommended use of this preparation is as a FIRE EXTINGUISHING AGENT.

Company Identification

Manufacturer/Supplier: Buckeye Fire Equipment Company
Address: 110 Kings Road, Kings Mountain, NC 28086
Prepared By: Buckeye Fire Equipment Company
Phone: (704) 739-7415
Email Address: bfec@buckeyef.com
Internet/Home Page: www.buckeyef.com

Emergency Telephone

CHEMTREC 1-800-424-9300

SECTION II. Hazard Identification

GHS – Classification

Acute Toxicity: Category 5
Eye Irritation: Category 2B
Skin Irritation: Category 3

GHS Label Symbol(s):



If Pressurized: Gas Under Pressure:



GHS Word(s): WARNING

Hazard Statements:

H303 May be harmful if swallowed.
H313 May be harmful in contact with skin.
H320 Causes eye irritation
H333 May be harmful if inhaled

Precautionary Statements:

P101 If medical advice is needed, have product container or label at hand.
P102 Keep out of reach of children.
P234 Keep in original container.
P251 Pressurized container; do not pierce or burn, even after use
P264 Wash hands and face thoroughly after handling
P301+322 If swallowed, drink 2-3 glasses of water.
P302+352 If on skin, wash with soap and water



SAFETY DATA SHEET LIQUID FIRE SUPPRESSION AGENT

Precautionary Statements

(cont):

P305+351+338	If in eyes, rinse cautiously with water for several minutes. Remove contact lenses if present and easy to do and continue to rinse.
P337+313	If eye irritation persists, get medical advice/attention.
P401+402+403	Store in original container in a dry, well ventilated place.

SECTION III. Composition/Information on Ingredients

Ingredient Name:	Potassium Carbonate (Potash).
Chemical Formula:	K_2CO_3 .
CAS No.:	584-08-7.
EINNECS Number:	209-529-3.
Concentration, Wt%:	43-45%

Ingredient Name:	Water.
Chemical Formula:	H ₂ O
CAS No.:	7732-18-5.
EINNECS Number:	231-791-2.
Concentration, Wt%:	58-60%

SECTION IV. First Aid Measures

Eye Contact:	Wash with water for a minimum of 15 minutes. If irritation persists, seek medical attention.
Skin Contact:	Wash affected area with soap and water. If irritation persists, seek medical attention.
Inhalation:	Remove from exposure. If irritation persists, seek medical attention.
Ingestion:	Dilute by drinking large quantities of water.

SECTION V. Firefighting Measures

This preparation is an extinguishing media.
There are NO extinguishing media which must not be used for safety reasons.
NO special protective equipment is needed for fire-fighters. Wear protective equipment appropriate for the fire conditions.

SECTION VI. Accidental Release Measures

Turn off or disconnect electrical sources in the immediate area.
For personal protection: Prevent skin and eye contact, see Heading 8.
Clean up: Use an absorbent material such as diatomaceous earth, sawdust, etc., and sweep up, see Heading 13. NO harm to the environment is expected from an accidental release of this preparation.



SECTION VII. Handling and Storage

Keep Separate from acids. See incompatibility information in Heading 10.
NO special conditions are needed for safe storage. See Heading 10 for incompatibilities. Store in original container.
Keep tightly closed until used. There is minimal danger to the environment from a storage release.

The intended or recommended use of this preparation is as a FIRE EXTINGUISHING AGENT.

SECTION VIII. Exposure Controls and Personal Protection

Exposure limit values

There are currently NO occupational exposure limit values for this preparation or any components.

Exposure Controls

Occupational exposure controls

Respiratory protection: Not expected to be needed. Vapors will be water.

Hand Protection: Use rubber gloves when handling the preparation.

Eye Protection: Use safety glasses with side shields or safety goggles.

Skin Protection: No special equipment is needed.

Environmental exposure controls: No special equipment is needed.

SECTION IX. Physical and Chemical Properties

General Information

Appearance: Clear colorless liquid
Odor: None

Important health, safety, and environmental information

pH: 11.5 ± 1 (at 25 ° C)
Boiling point/boiling range: About 110 ° C (About 230 ° F)
Flash point: None to boiling.
Flammability (solid/gas): Not flammable
Explosive properties: Not explosive
Oxidizing properties: Not an oxidizer
Vapor Pressure: About 12mm Hg
Relative Density (Water=1) About 1.4
Solubility:
- Water Solubility: Completely soluble
- Fat Solubility: Not soluble
Partition coefficient, n-octanol/water: Not
determined Viscosity: Not
determined
Vapor density: Not
determined Evaporation rate (Butyl acetate = 1): N/A

Other Information

Auto ignition temperature: Does not ignite



SECTION X. Stability and Reactivity

Conditions to avoid

There are no known conditions such as temperature, pressure, light, shock, etc., which may cause a dangerous reaction.

Materials to avoid

Ammonium compounds, acids, corrodible metals (copper aluminum).

Reactive metals may react with the water in this preparation.

Energized electrical equipment may cause a shock hazard when this fire extinguishing agent is used.

Hazardous decomposition product

Normally stable

Hazardous polymerization will not occur.

Combustion or decomposition products include CO₂, CO.

SECTION XI. Toxicological Information

Toxicity data has not been determined for this product.

Potassium Carbonate: Oral LD₅₀ (rat) = 1870 mg/kg.

SECTION XII. Ecological Information Ecotoxicity:

Not determined

Mobility: Not determined

Persistence and degradability: Not determined

Bioaccumulative potential: Not determined **Other adverse effects**

Ozone depletion potential:

N

one Photochemical ozone creation potential:

N

one

Global warming potential:

Release of carbon dioxide by thermal decomposition or

chemical reaction could contribute to global warming.

SECTION XIII. Disposal Considerations

No harm to the environment is expected from this preparation.

Dispose of in compliance with national, regional, and local provisions that may be in force.

SECTION XIV. Transportation Information

Hazard Class or Division: Not hazardous There are no special precautions known.

No harm to the environment is expected from this preparation.

Please Note: Although this material is not considered hazardous, when contained in a stored pressure vessel pressurized with a nonflammable gas, the vessel itself is considered a hazardous material by the U.S. Department of Transportation (USDOT) and Transport Canada (TC). The proper shipping name shall be Nitrogen, 2.2 Compressed, and the UN Identification Number is UN 1066.



SECTION XV. Regulatory Information

EU Classification:	Irritant
Exposure Limit Values:	None
All components are included in EINECS Inventory or are exempt from listing	
All components are included in the TSCA Inventory or are exempt from listing.	
Canadian DSL (Domestic Substances List):	All components are included in the DSL or are exempt from listing.
Environmental restrictions:	None are known
Restrictions on Marketing and Use:	None are

known Refer to any other national measures that may be relevant

SECTION XVI. Other Information

This Safety Data Sheet prepared in accordance with OSHA’s Hazard Communication Standard (29 CFR 1910.1200) and the Globally Harmonized System of Classification and Labelling of Chemicals (GHS).

EU Classification:	
Irritant R 36/37/38	Irritating to eyes, respiratory system, and skin.
S 26	In case of contact with eyes, rinse immediately with plenty of water and seek medical advice
S 36	Wear suitable protective clothing

(HMIS) HAZARDOUS MATERIAL IDENTIFICATION SYSTEM RATINGS:		
HEALTH:	<u>2</u>	4. Severe Hazard
FLAMMABILITY:	<u>0</u>	3. Serious Hazard
REACTIVITY:	<u>0</u>	2. Moderate Hazard
		1. Slight Hazard
		0. Minimal Hazard

(WHMIS) CANADIAN WORKPLACE HAZARDOUS MATERIAL IDENTIFICATION SYSTEM RATINGS:	
This product is rated: D2B – Product may irritate skin, eyes, or mucous membrane.	

THE ABOVE INFORMATION IS BELIEVED TO BE CORRECT BUT DOES NOT PURPORT TO BE ALL INCLUSIVE AND SHALL BE USED ONLY AS A GUIDE. BUCKEYE FIRE EQUIPMENT COMPANY SHALL NOT BE HELD LIABLE FOR ANY DAMAGE RESULTING FROM HANDLING OR FROM CONTACT WITH THE ABOVE PRODUCT.

N/A = Not Applicable

NDA = No Data Available

SDS available at www.buckeyef.com



This Page Intentionally Blank.



Appendix B

System Accessories and Supplemental Information

Hood Quickseals

The NFPA 96 Standard For Ventilation Control and Fire Protection of Commercial Cooking Operations requires that all hood penetrations be sealed by a liquid-tight, continuous external weld or a Listed mechanical device providing a liquid-tight seal. Liquid-tight sealing devices for pipe and conduit are available in either threaded or compression styles. See chart below for more details.

Buckeye Model Number	Hood Quickseal Description	Drill Hole Size inches (cm)
QS-38P	Threaded for 3/8" (17.1 mm OD) PIPE	1-1/8 (2.9)
QS-50P	Threaded for 1/2" (21.3 mm OD) PIPE	1-1/8 (2.9)
CQS-38P	Compression Type for 3/8" (17.1 mm OD) PIPE	1-1/8 (2.9)
CQS-50P	Compression Type for 1/2" (21.3 mm OD) PIPE	1-1/8 (2.9)
CQS-50C	Compression Type for 1/2" (1.3 cm) EMT	1-1/8 (2.9)
QS-CPA	Corner Pulley Adapter	1-1/8 (2.9)

Model BFR-PG 195 psi Pressure Gauge

The **Model BFR-PG** replacement pressure gauge is a stainless-steel pressure gauge with an internal pressure snubber designed specifically for the *Kitchen Mister* cylinders. The **Model BFR-PG** is the only pressure gauge approved for use with the *Kitchen Mister* System.

Model BFR-OM Owner's Manual

A *Kitchen Mister* Owner's Manual (**Model BFR-OM**) is supplied with every cylinder or can be purchased separately. The Owner's Manual must be given to restaurant owner or the restaurant owner's designated representative after system installation is complete (as per NFPA 17A Standard for Wet Chemical Extinguishing Systems and NFPA 96 Standard for Ventilation Control and Fire Protection of Commercial Cooking Operations.) and thoroughly reviewed with them.

Models BFR-5T, BFR-10T, BFR-15T and BFR20T Restaurant Test Cylinders

The **Model BFR-5T, BFR-10T, BFR-15T and BFR-20T** restaurant test cylinders are the same size as their corresponding filled cylinder except they are empty so they can be used to either test the system or discharge air or nitrogen through the system piping.

Model BFR-TVA Test Valve Assembly

The **Model BFR-TVA** Test Valve Assembly can be installed on the Valve Cap Assembly (**Model BFR-CAP**) to determine if the pneumatic connection is unobstructed and free from leakage. Detailed instructions for pneumatic testing are provided with the Test Valve Assembly. See **Figure B-1** and **Figure B-2**.

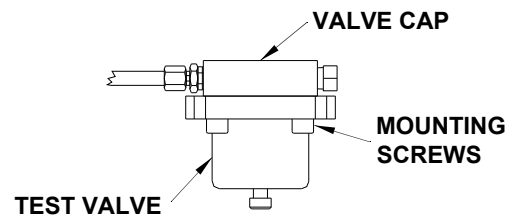

Figure B-1.
Model BFR-TVA,
Test Valve Assembly

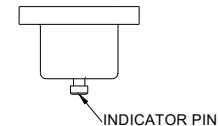

Figure B-2.
Model BFR-TVA,
Installation of Test Valve Assembly

Tee Pulley Installation

The **Model BFR-TP1** Tee Pulley is used to connect two (2) remote pull stations and/or two (2) mechanical gas valves to a single Systems Releasing Module(s).

When a tee pulley is used to connect two (2) gas valves or mechanical pull stations to a single Systems Releasing Module(s), it is considered two (2) corner pulleys when calculating system limitations.

A tee pulley that is used to connect two (2) gas valves can only be used on gas valves with same stem travel. The following combinations are acceptable:

- Two 3/4" (2.0 cm) valves.
- Two of any combination of 1" (2.5 cm), 1-1/4" (3.2 cm), or 1-1/2" (3.8 cm).
- Two 2" (5 cm) valves.
- Two of any combination of 2-1/2" (6.4 cm) or 3" (7.6 cm) valves.

To install the tee pulley, the cable proceeding from the Systems Releasing Module(s) must enter the branch



(side outlet) of the tee pulley. Proper installation is as shown in the following diagram. See **Figure B-3**.

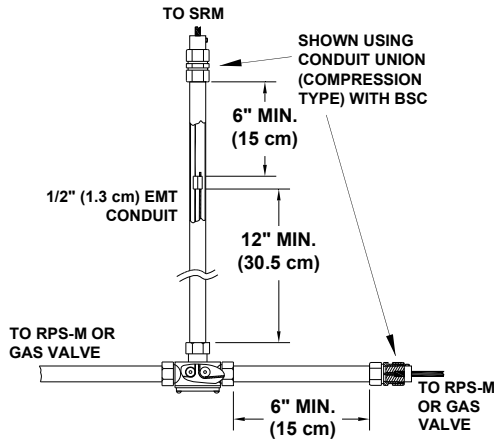

Figure B-3.
Model BFR-TP1
Tee Pulley Installation

CAUTION

The Model BFR-TP1 Tee Pulley must never be used to connect two fusible link lines to the Systems Releasing Module(s).

WC-116-100, Wire Crimps for 1/16\"
(0.16 cm) Cable (100 per package)

The Model WC-116-100 is a tin-plated copper sleeves specifically designed to be used with 1/16" (0.16 cm) stainless steel cable.

Flexible Hex Driver

The Model BFR-FHD is a flexible 3/16" (0.5 cm) hex wrench that is used to facilitate the tightening of the hex screws used to connect the Systems Releasing Module(s) to the cylinder valve.

NOTE: The flexible end of the hex wrench should only be used to start the screw, final tightening must be done with the rigid part of the hex wrench to insure a tight seal between the SRM and cylinder valve. See **Figure B-4**.

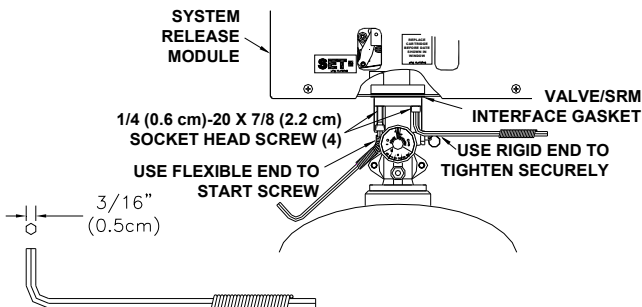

Figure B-4.
Model BFR-FHD
Flexible Hex Driver

CAUTION
Failure to properly tighten hex screws may cause system failure.

Upright Broiler Stainless Steel Nozzle Cap

Model BFR-UBC Upright Broiler Cap is a stainless-steel nozzle cap that can be used in place of the standard tethered silicone rubber blow off cap that comes with the nozzle.

This stainless-steel nozzle cap can only be used for the upright broiler or for installations that involve extreme heat that makes the standard nozzle cap ineffective.

The **Model BFR-UBC-10** comes complete with ten (10) stainless steel blow-off caps and ten (10) O-rings. An O-ring must be installed in the slot provided in the nozzle tip as shown in **Figure B-5**.

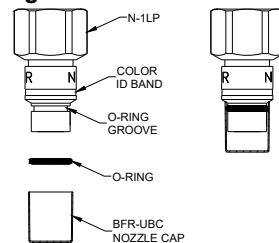

Figure B-5.
Model BFR-UBC
Nozzle Cap Installation

The **Model BFR-UBCT** is a metal blow-off cap and O-ring, but with a stainless-steel tether attached to it. This will allow the tether to be attached to the piping that the nozzle is installed on. See **Figure B-6**. The **Model BFR-UBCT-5** comes with five (5) caps and O-rings.

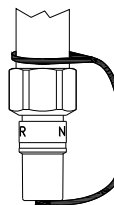

Figure B-6.
Model BFR-UBCT
Tether Nozzle Cap Installation

NOTE: Because of the high heat this type of nozzle cap may be exposed to, the **Model BFR-UBC** and **BFR-UBCT**, along with the O-ring must be inspected semi-annually. The cap must be removed, cleaned and checked to assure it slides easily on and off the nozzle body. If the cap does not slide easily off the nozzle tip, the O-ring and cap must be replaced.



Stainless Steel Flexible Discharge Hose

Model BFR-SSFH is a stainless steel braided flexible discharge hose that can be used with the Kitchen Mister System. It is designed to allow for the movement of appliances with attached nozzles and for the movement of appliances for cleaning and maintenance. The **Model BFR-SSFH** is 6 feet (1.8 m) in length with 3/8" NPT male fittings installed on each end of the hose. The hose, outer braiding and fittings are all made from stainless-steel. See **Figure B-7**.

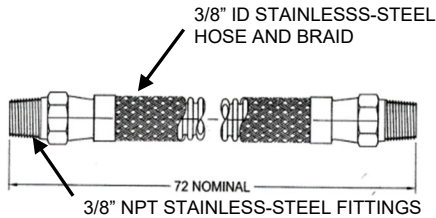

Figure B-7.
Model BFR-SSFH
STAINLESS-STEEL FLEXIBLE HOSE

The **Model BFR-SSFH** can be used as a direct substitute for Schedule 40 black, chrome plated, or stainless-steel distribution pipe.



Keeper Pin (SRM and SRM-D Only)

For the Model SRM and Model SRM-D Systems Releasing Module(s), the Kitchen Mister System uses a proprietary keeper pin (**Model No. SRM-KPIN**) to prevent the full actuation of the SRM and SRM-D. See **Figure B-8**.

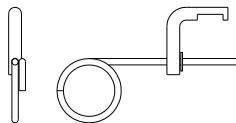

Figure B-8.
Model SRM-KPIN
Keeper Pin

In order to properly secure the Systems Releasing Module(s) with the Keeper Pin, follow these steps:

1. Unscrew nitrogen cartridge completely from manifold block and set aside or if out of date, empty cartridge and discard.
2. The Keeper Pin hole is located above Catch. Once the keeper pin has been located, insert the BFR-FHD (or 3/8" Drive ratchet and 3/16" Hex bit) into Detection Arm and rotate to the right so that the detection Arm comes in connect with mounting block. See **Figure B-9**.

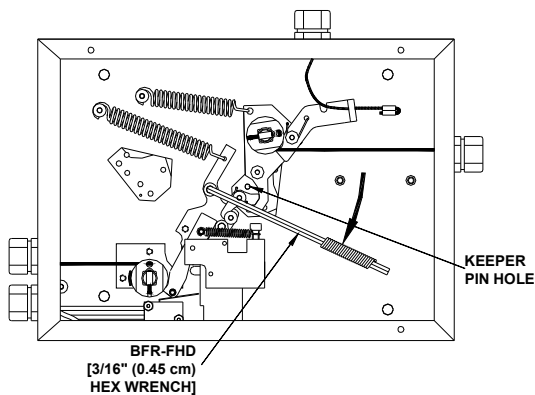

Figure B-9.
Keeper Pin Location

3. Insert the Keeper Pin into the keeper pin hole and slide the hook of the Keeper Pin over the Detection Arm. The Keeper Pin hook must engage the Detection Arm completely. See **Figure B-10**.

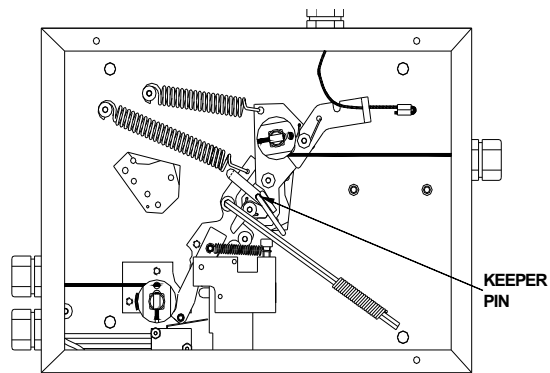

Figure B-10.
Inserting Keeper Pin

4. Remove hex wrench. **Note** gap between Catch and Detection Arm. The detection line can now be released without actuating the gas valve or micro switches. See **Figure B-11**

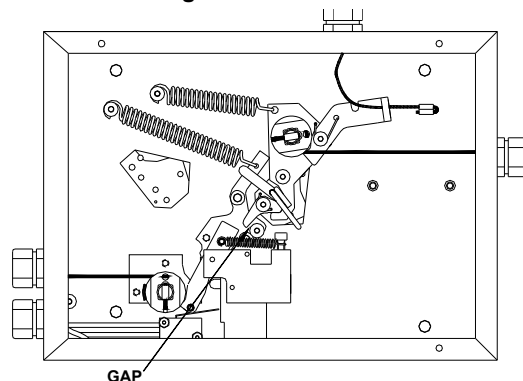

Figure B-11.
Keeper Pin Installed

To remove the Keeper Pin:

1. Reset the Fusible Link Line by rotating the Detection Arm Assembly until all the slack has been removed from the fusible link line and the Detection Arm hits the stop and the Catch is engaged. See **Figure B-12**.

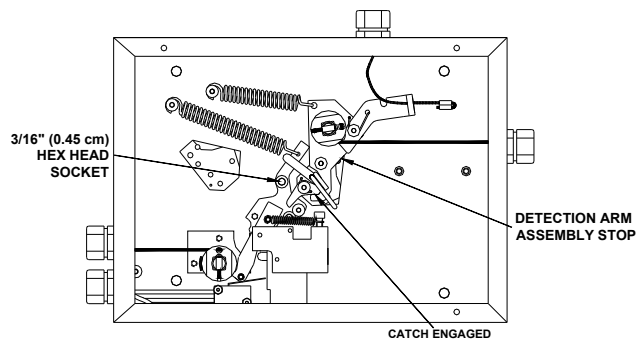

Figure B-12.
Locating 3/16" (0.45 cm) Hex Head



2. Locate the 3/16" Hex Head Socket and insert the BFR-FHD into it. Rotate the BFR-FHD clockwise and disengage the Keeper Pin hook from the Detection Trigger. Remove the Keeper Pin assembly slowly rotate the BFR-FHD counter-clockwise until the Detection Trigger engages the Catch. See **Figure B-13**.

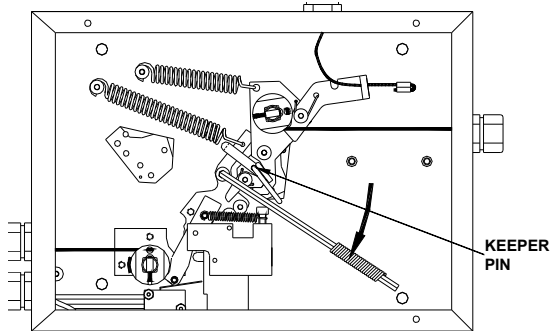

Figure B-13.
Keeper Pin Installed

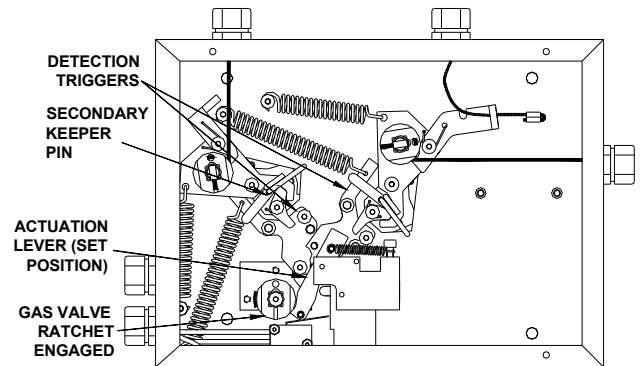

Figure B-15.
Installation of Secondary Keeper Pin

CAUTION

Before installing the Nitrogen Actuation Cartridge, the installer shall inspect the sealing cap for punctures or other damage and verify that the cartridge weighs more than the stated minimum gross weight stamped on the cartridge. If any evidence of damage, puncture or if the cartridge weighs less than minimum gross weight, empty cartridge then discard and replace.

3. Remove BFR-FHD and check that control head is now in the SET position.
4. Replace nitrogen Cartridge and put SRM back into service.

The SRM-D follows the same procedure as the SRM. Once the primary detection line is secured, the secondary line can be secured following the same procedure given for the SRM primary line. Refer to **Figures B-14 and B-15** for location of secondary keeper pin.

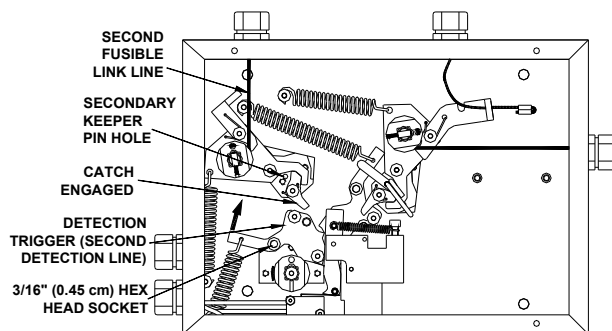

Figure B-14.
Locating Secondary Keeper Pin Hole



Keeper Pin (SRM2-M, SRM2-E-24 and SRM2-E-120 Only)

For the **Model SRM2-M, Model SRM2-E-24** and **Model SRM2-E-120** Systems Releasing Module(s), the Kitchen Mister System uses a proprietary keeper pin (**Model No. SRM2-KPIN**) to prevent the full actuation of the SRM2s. See **Figure B-16**.

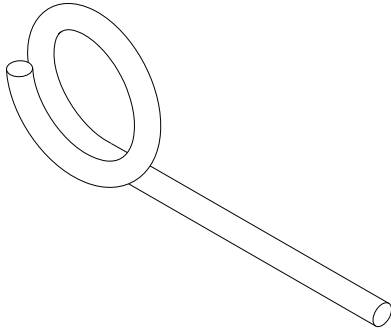

Figure B-16.
Model SRM2-KPIN, Keeper Pin

In order to properly secure the SRM2 Systems Releasing Module(s) with a Keeper Pin, while the SRM2 is set the SRM2-KPIN must be completely inserted in the keeper pin hole shown in **Figure B-17**.

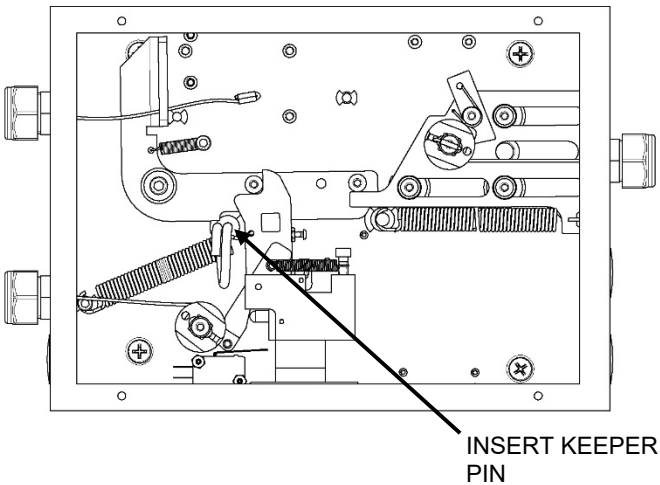

Figure B-17.
Model SRM2-M with SRM2-KPIN Installed



This Page Intentionally Blank.